

# SITS

*The best indoor workout solution for seniors*



# Project brief

SITS stands for Senior Indoor Training System. It is a home workout system specially designed for the youngest seniors to let them exercise safely and gain their motivation and confidence of exercising.



# Insights

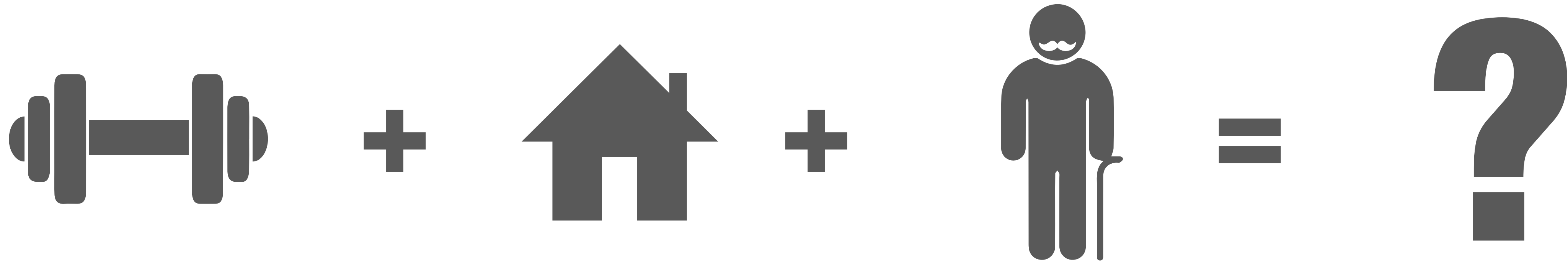

Wellness industry has experienced a huge impact under the pandemic

Daily work out is extensively shifting to indoor

Seniors are being left behind in this transition

How might we help the elderly exercise safely and actively at home?



## They are stronger than you thought

-getting old doesn't mean  
getting decrepit



## The sad fact

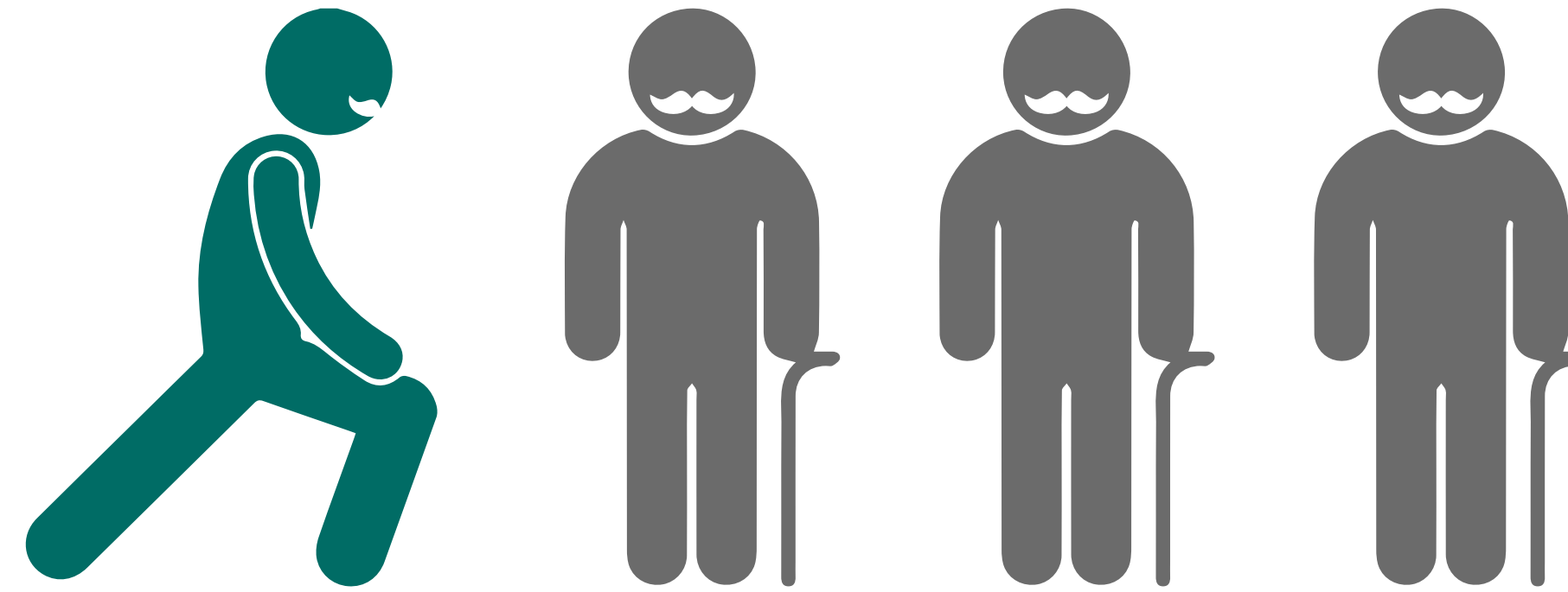

However, only 25% of them would exercise regularly.

# The youngest-old people

65-74  
youngest-old

75-84  
middle-old

65-74  
oldest-old



# Three crucial kinds of training for seniors



**Endurance**



**Strength & balance**



**Flexibility**

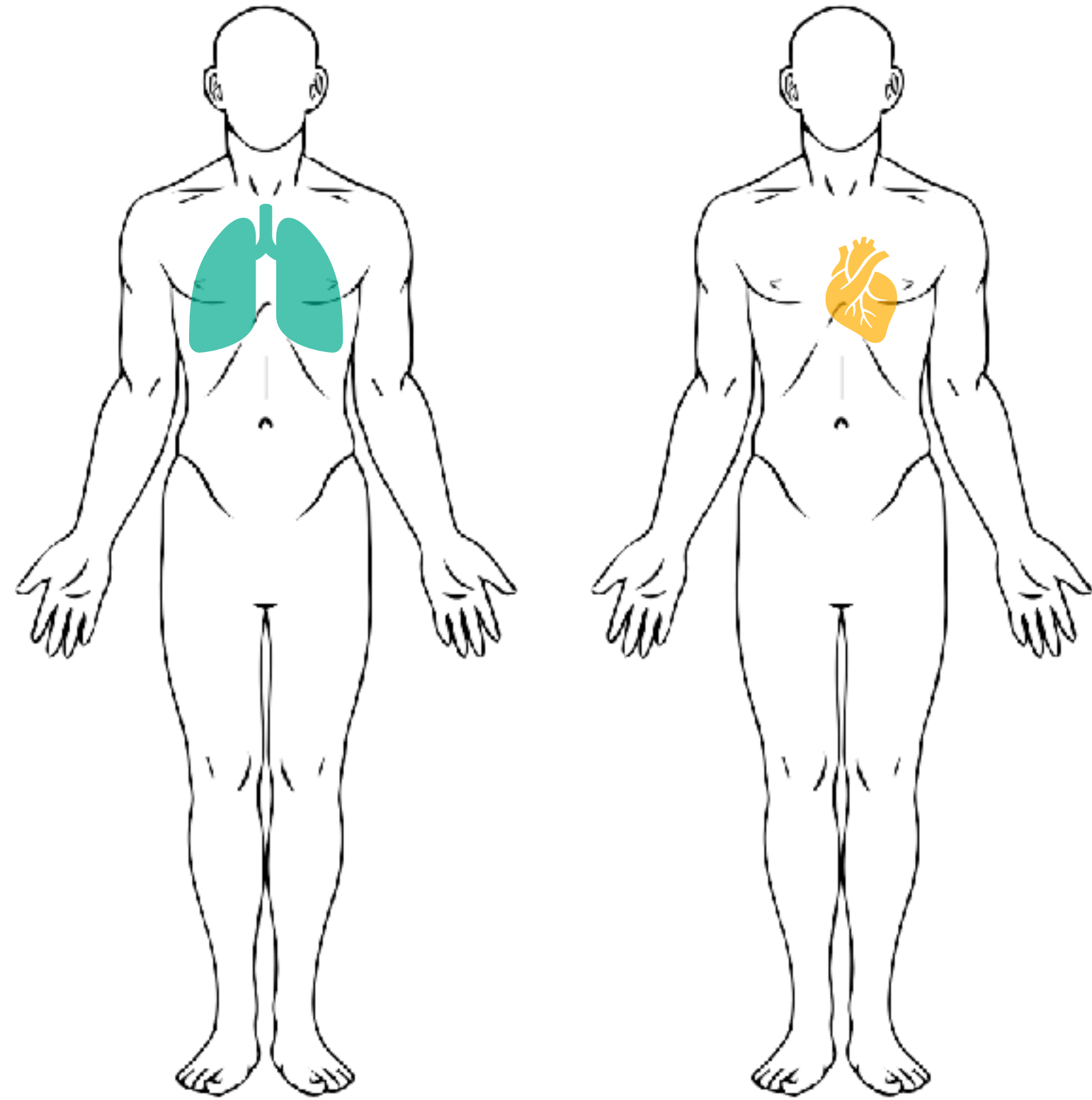

## Endurance training

Jogging

Walking

Swimming

Hiking

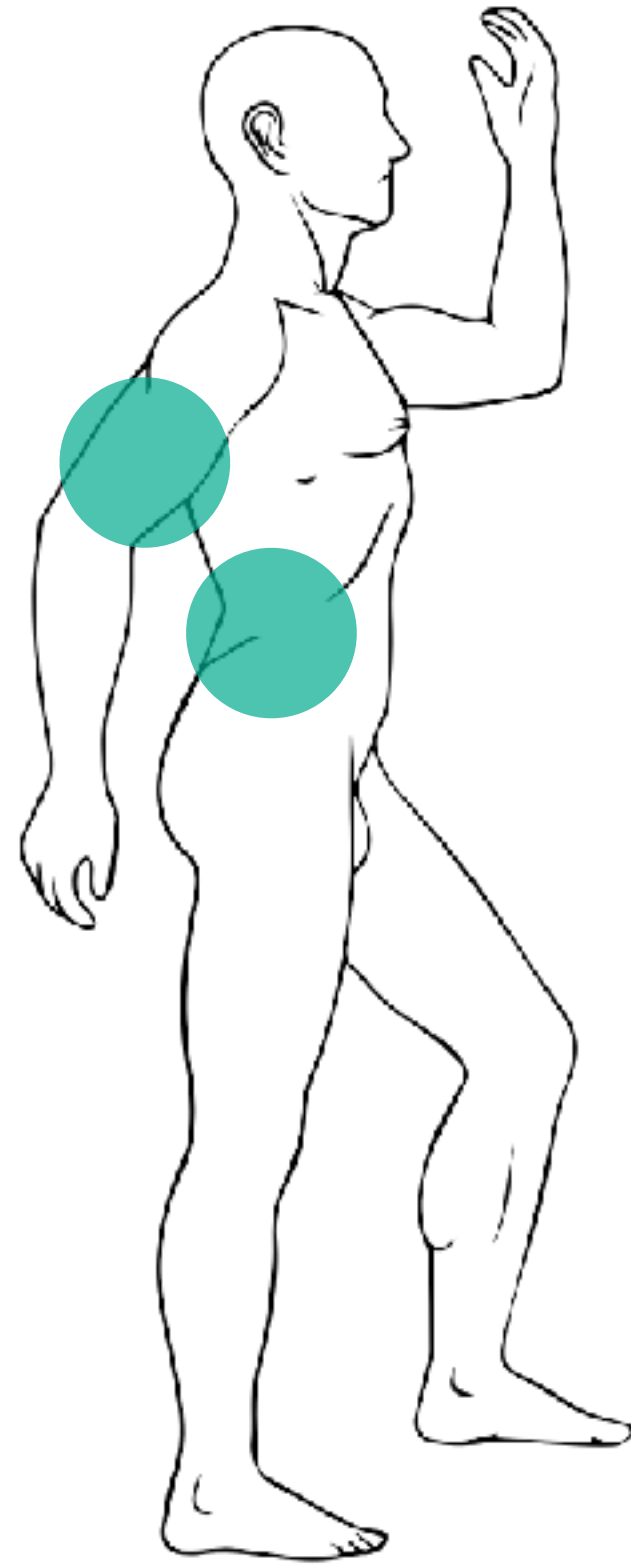
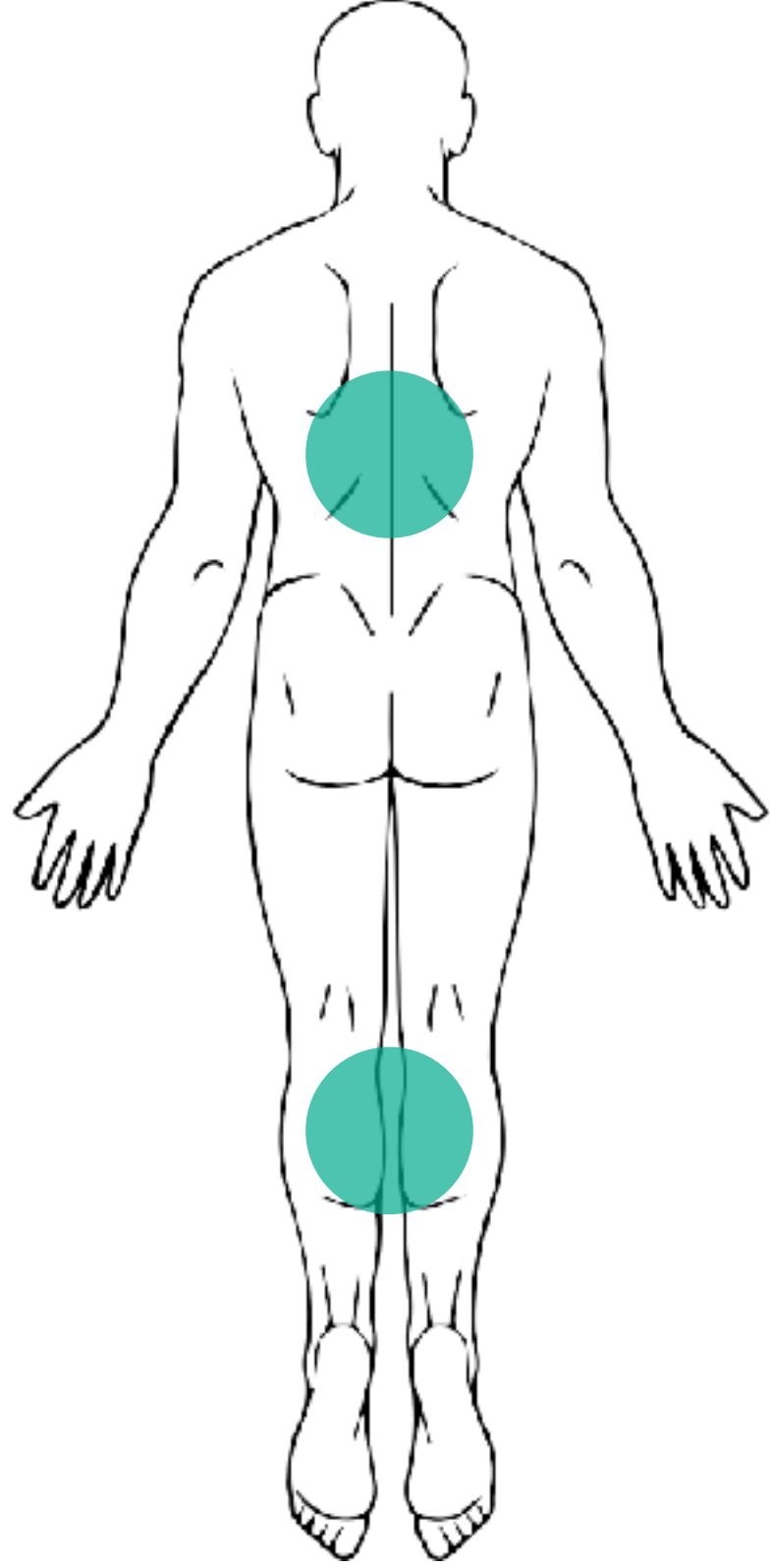
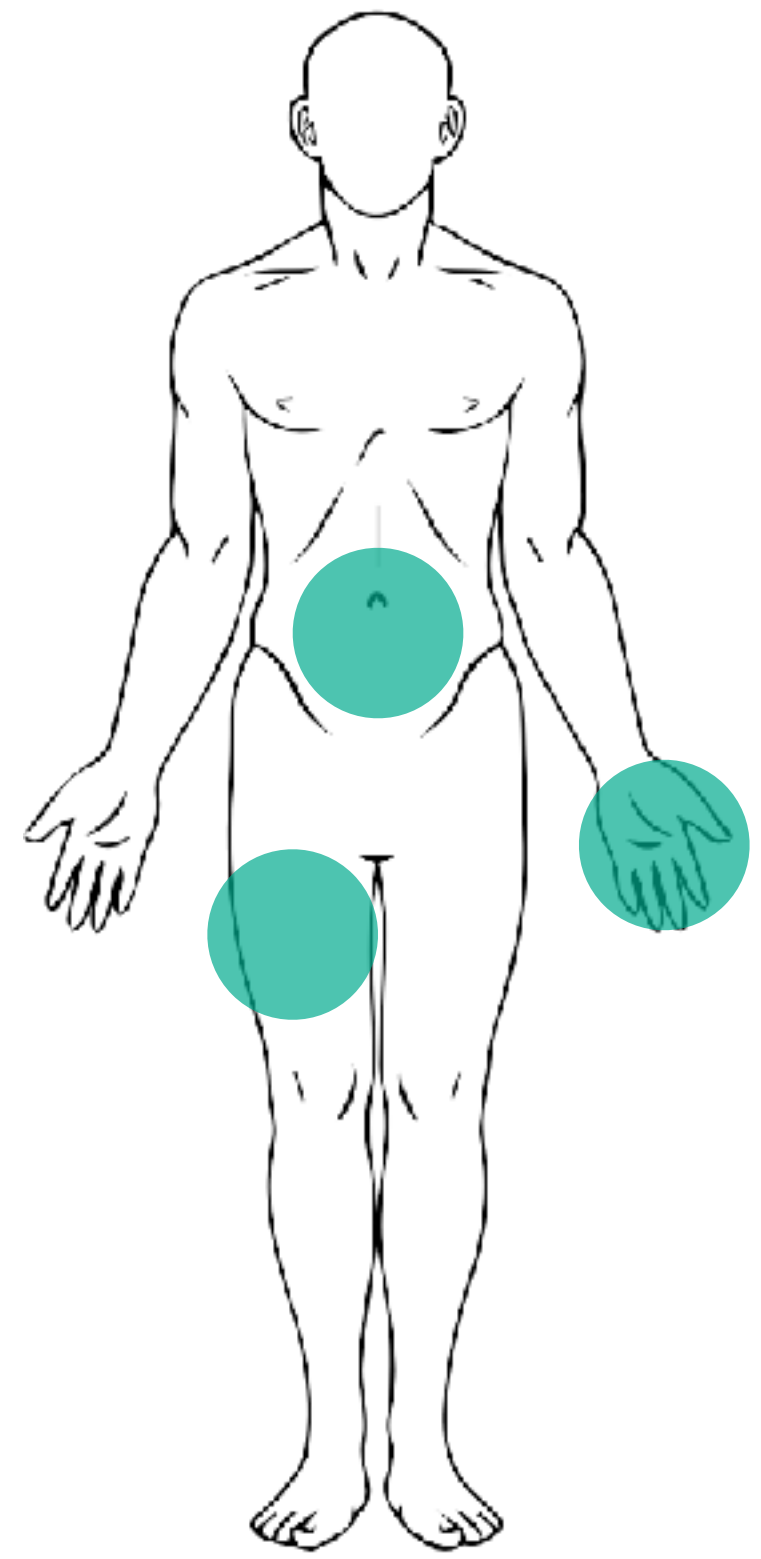

## Strength & balance training

Thighs  
Fingers  
Back  
Lower legs  
Waist  
Arm  
Core

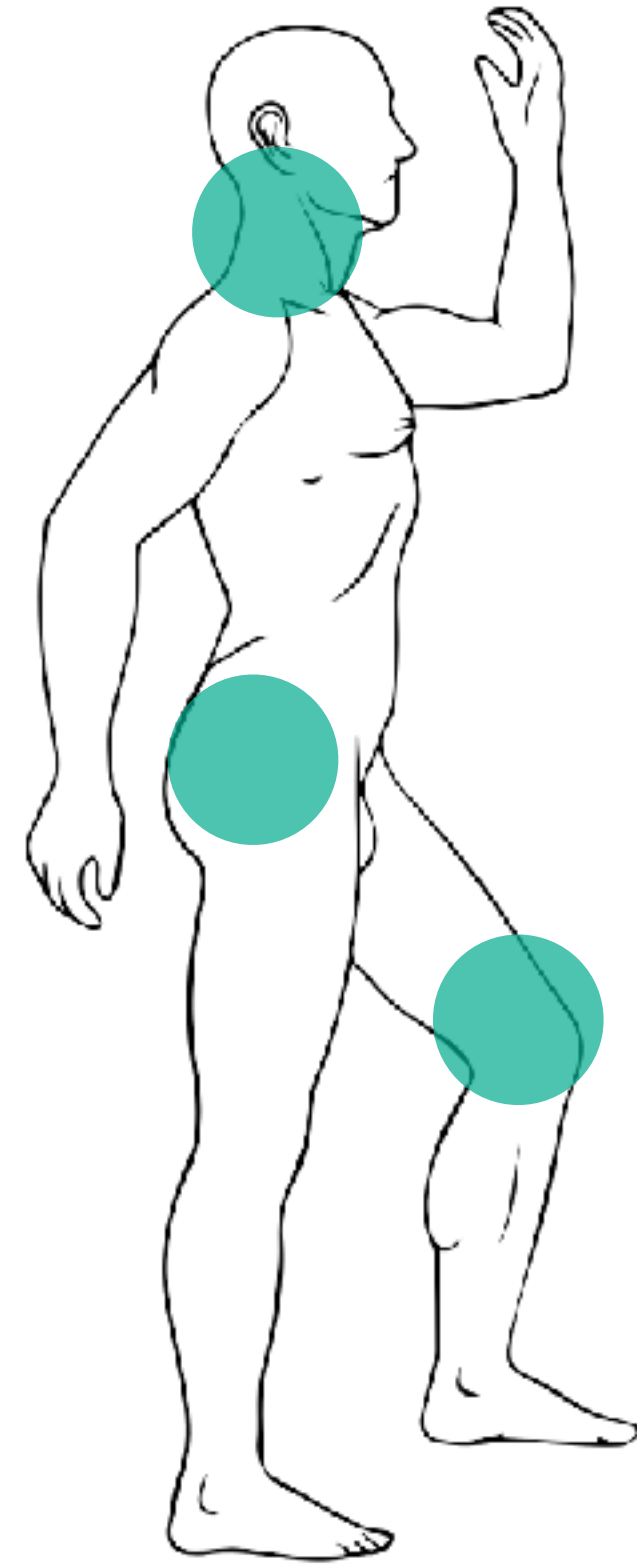
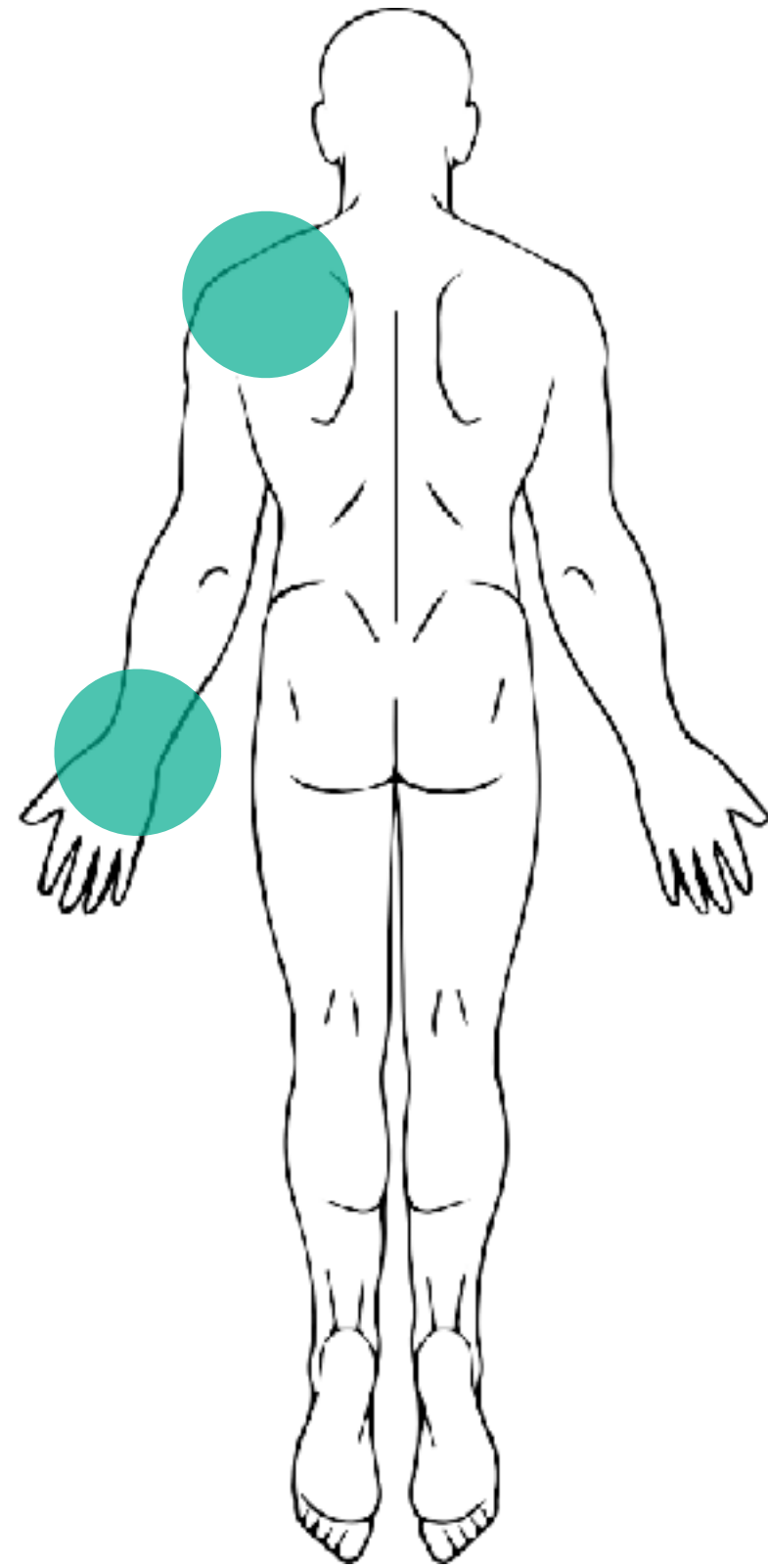
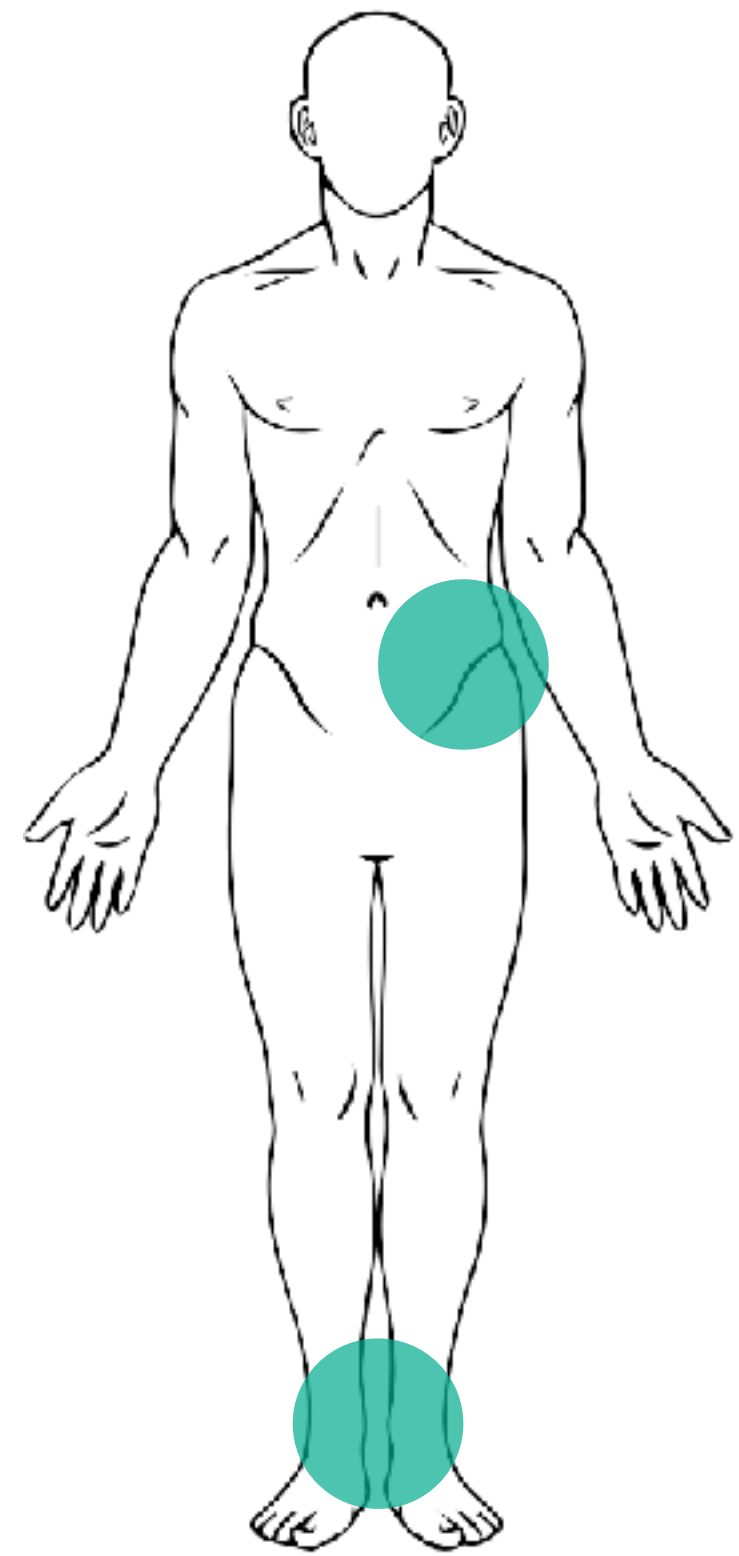

## Flexibility training

Ankles  
Wrists  
Shoulders  
Neck  
Hip  
Haunch  
Knees

# Experts interview

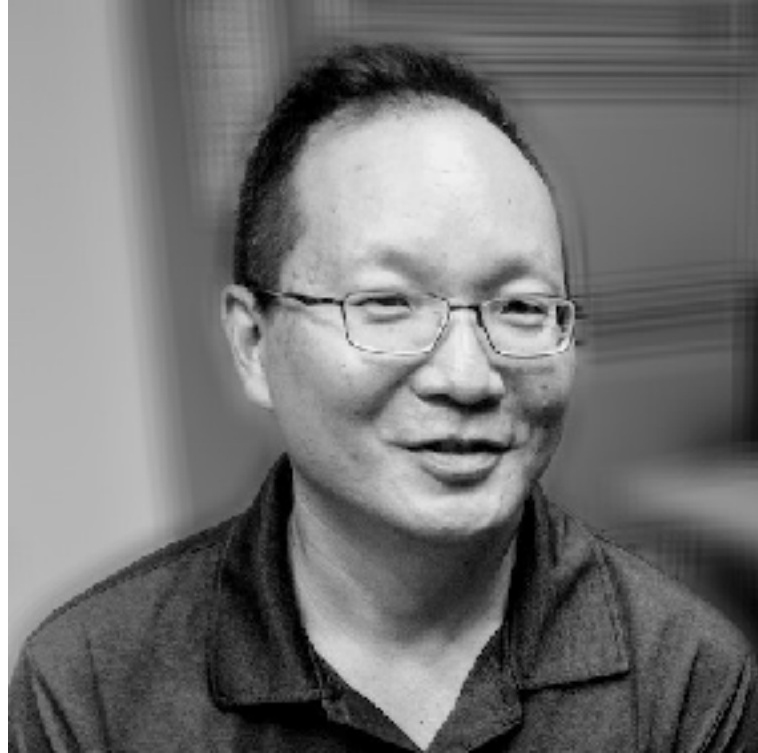

**Andy Lin**  
Rehabilitation  
Engineer

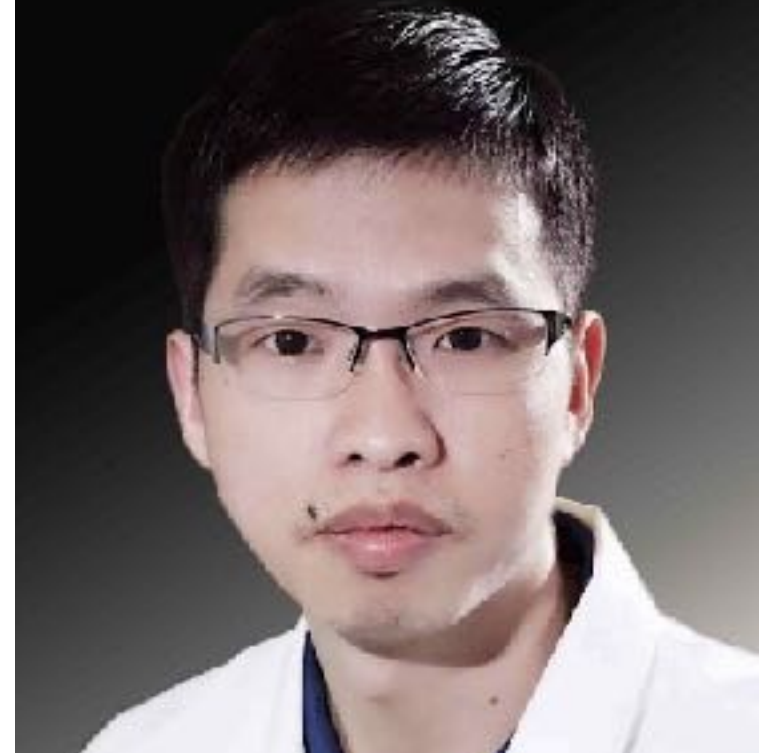

**Dongyang Chen**  
Chief physician of  
joint surgery and  
sports medicine

“The exercise ability of seniors highly depends on each individual.”

“The exercises for seniors should be much less intensive and slower and more continuous.”

“The core training is very beneficial for balance ability.”

“Exercise that works on different parts of the body simultaneously is more appropriate.”

**- Slow and gentle**

**- Protective**

**- Flexible**

# Early stage ideation

WALKING PAD WITH STICKS  
GAIN THE BODY COORDINATION

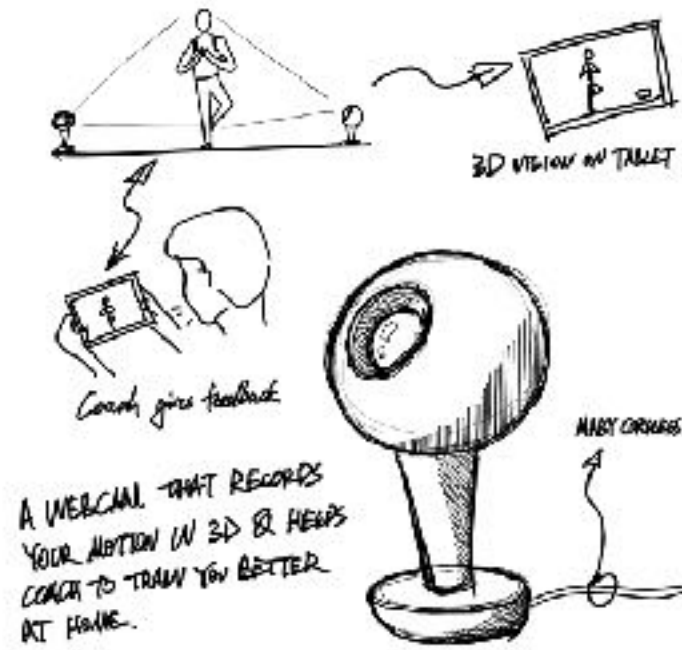
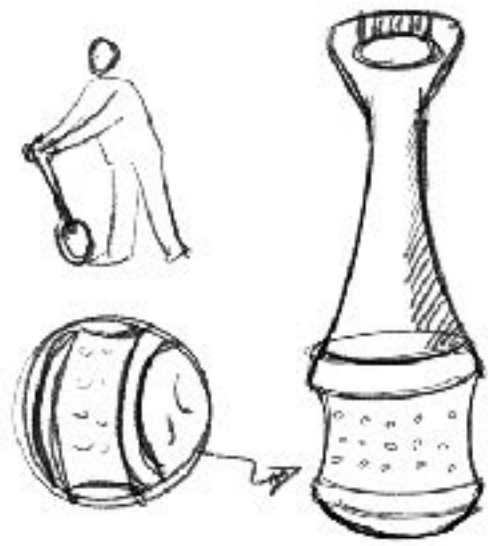
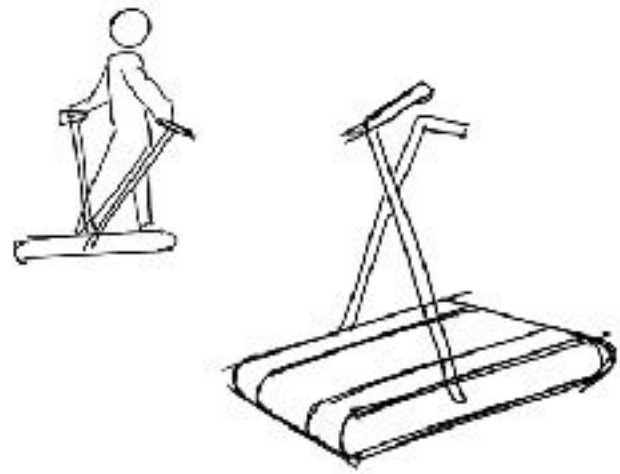

A GLOVE THAT TRACKS YOUR MOTION AND MUSCLE MOVEMENTS

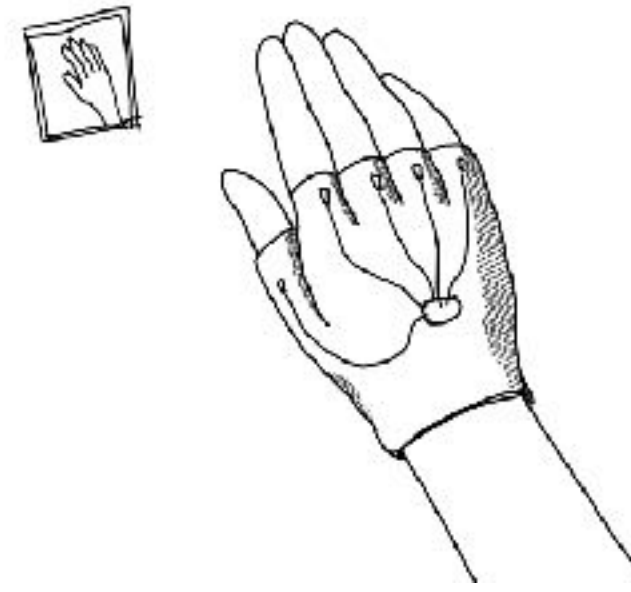

A TRACKER THAT CAN BE WORN ON WRIST OR ANKLE

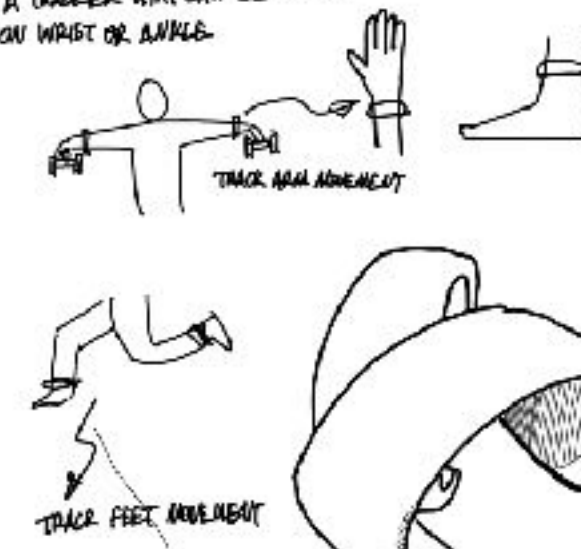

AN AR GOGGLE THAT ALLOWS YOU TO TRAIN VIRTUALLY WITH YOUR FRIENDS

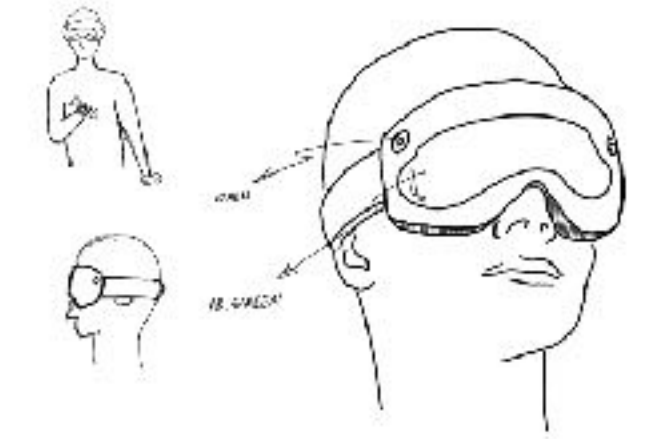

BALANCE TRAINING SHAPE



BALANCE TRAINING MACHINE



BALANCE TRAINING BARBELL

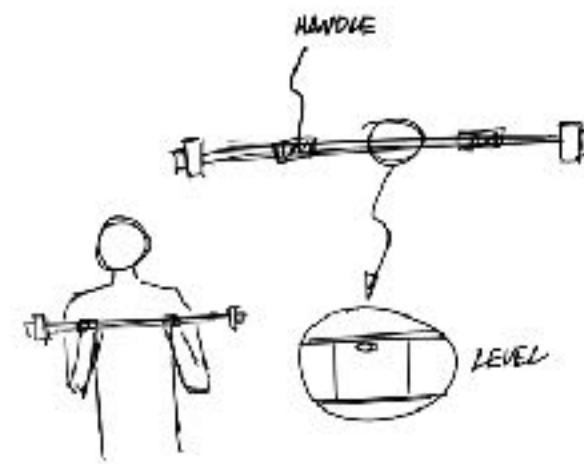

LEG STRENGTH TRAINING

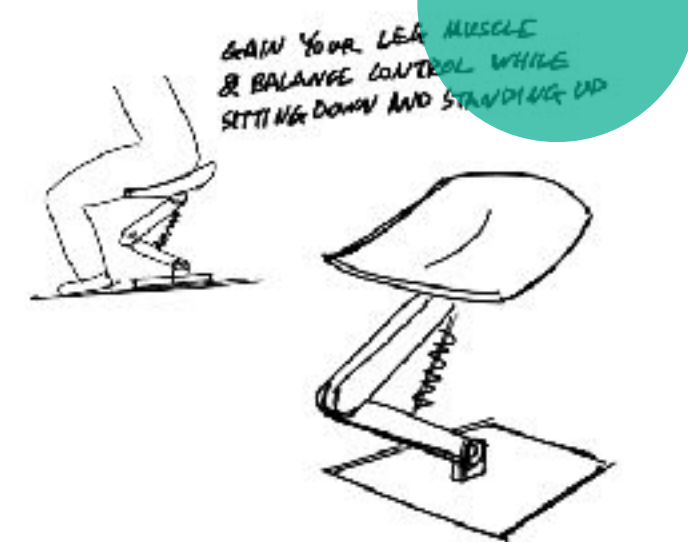

BALANCE TRAINING WALKING MACHINE

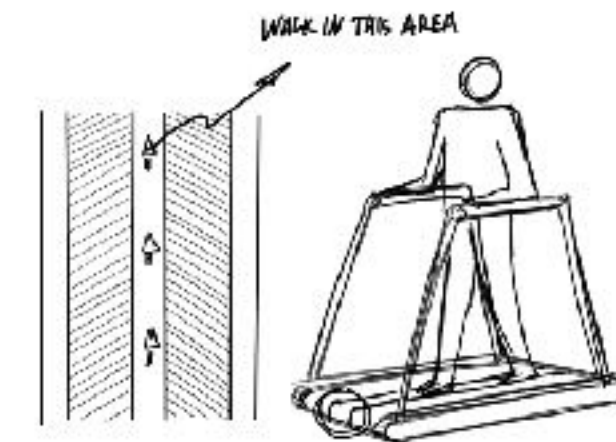

REACTION TRAINING

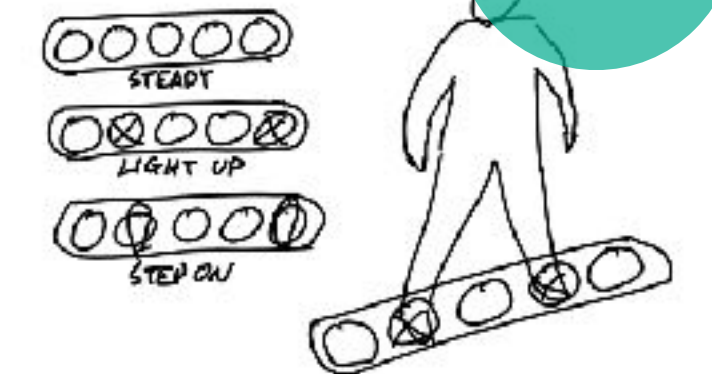

BALANCE TRAINING STANDING PAD

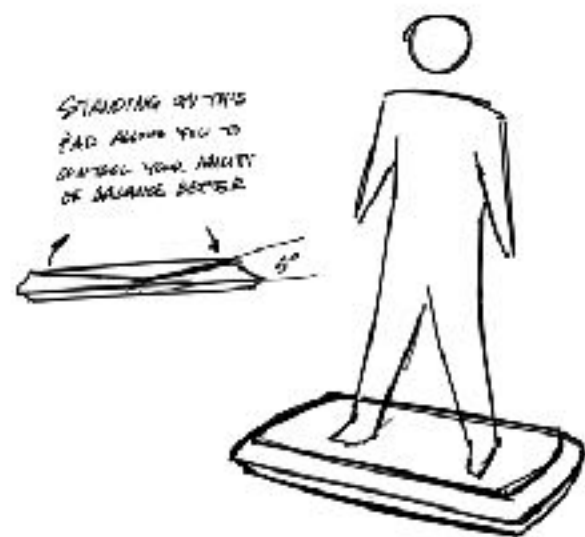

STANDING TRAINING AIR PAD



BALANCE GAME

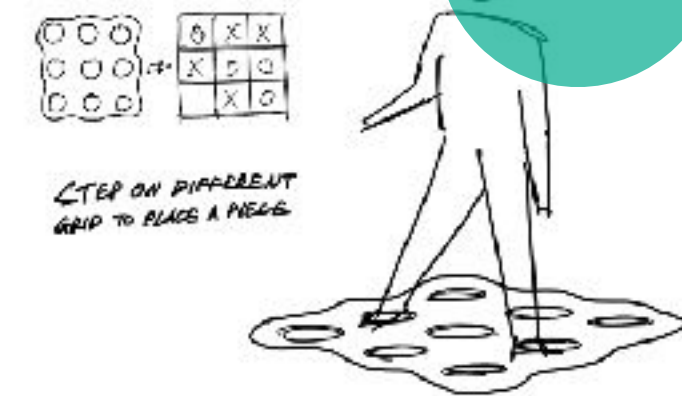

BALANCE TRAINING TOOL

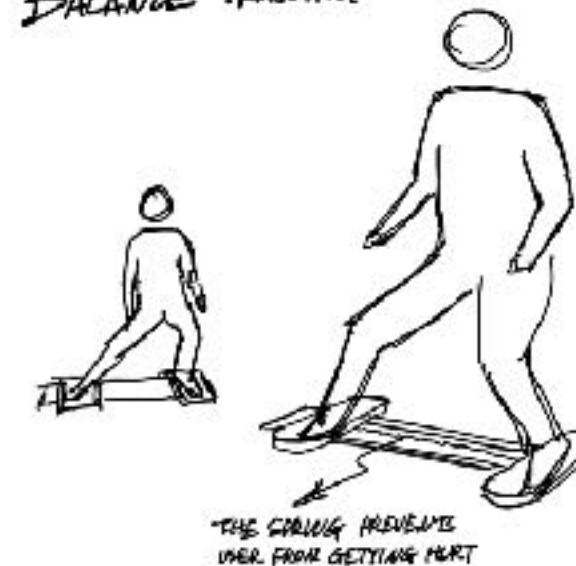

SLOW WALKING MACHINE

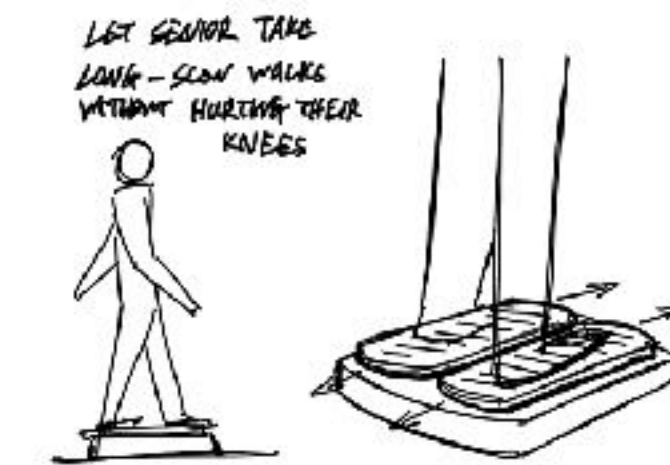

SITTING POSITION WALKING MACHINE

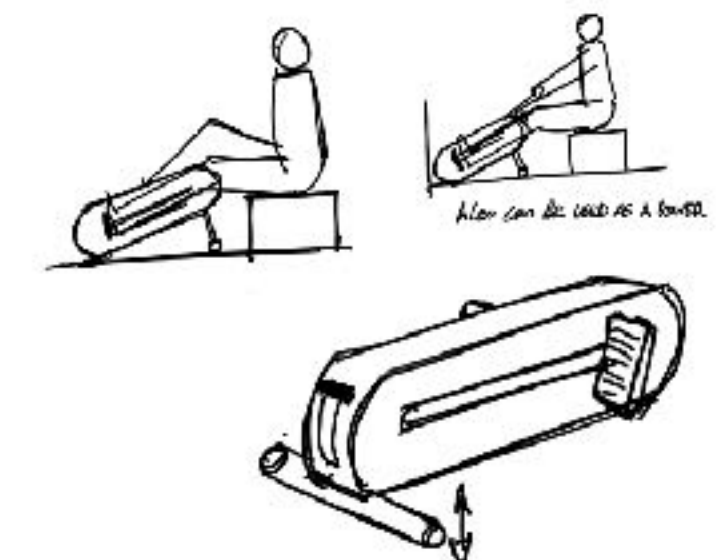

# Early stage ideation

Compact Bike

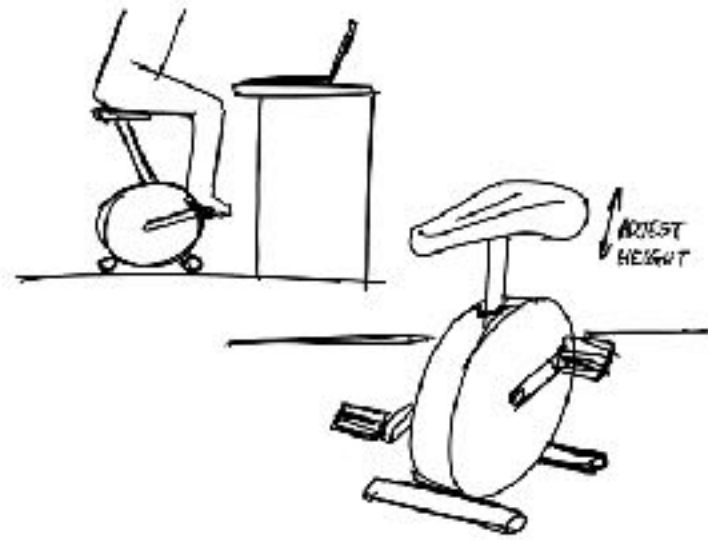

FITNESS GAME BALL



A WAIST BELT THAT TEACHES YOU HOW TO TRAIN YOUR BODY AND ALSO GIVES YOU PROTECTION

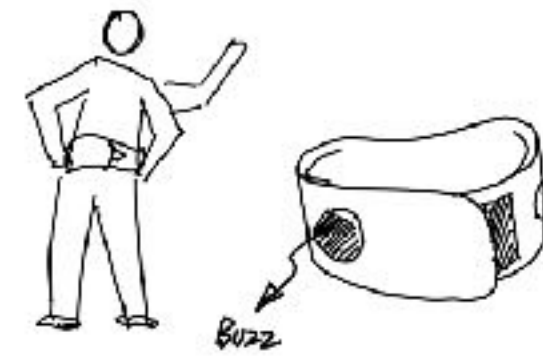

MULTI-FUNCTIONAL FITNESS EQUIPMENT

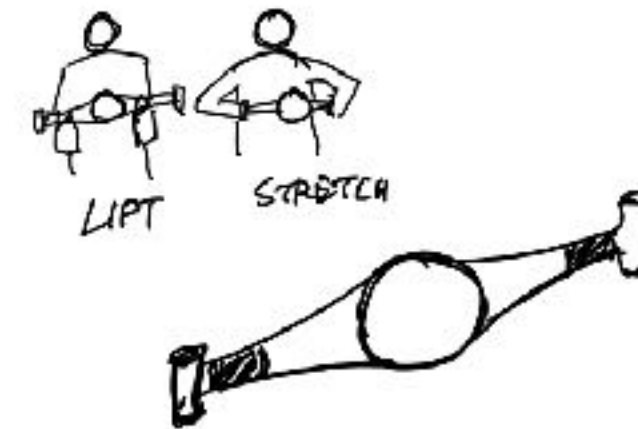

STRENGTH TRAINING TOOL

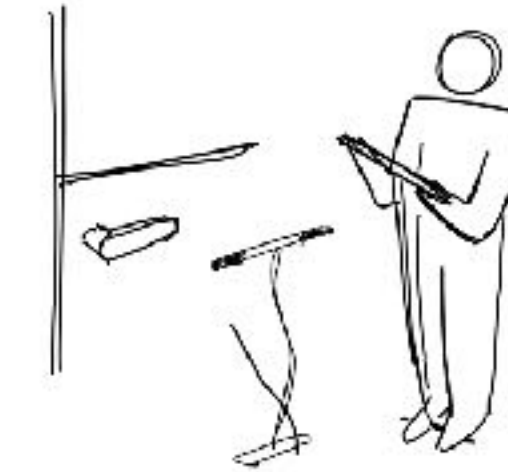

DESIGN DETAIL

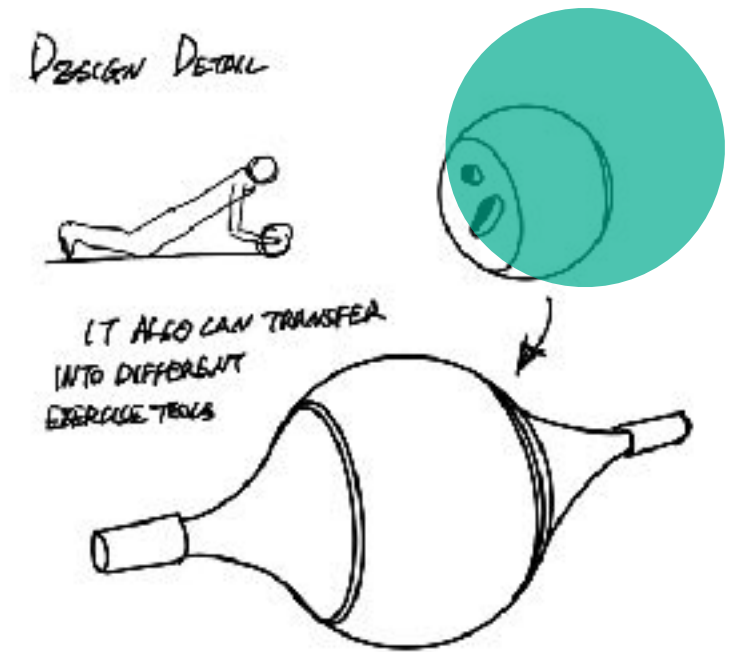

A NARROW WALKING MACHINE FOR SENIORS BALANCE TRAINING

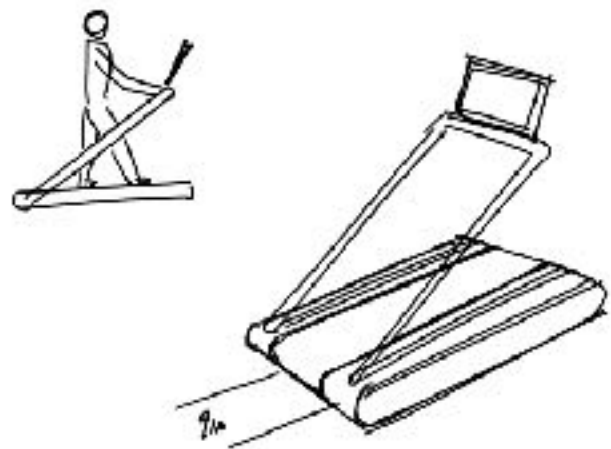

DESIGN DETAIL

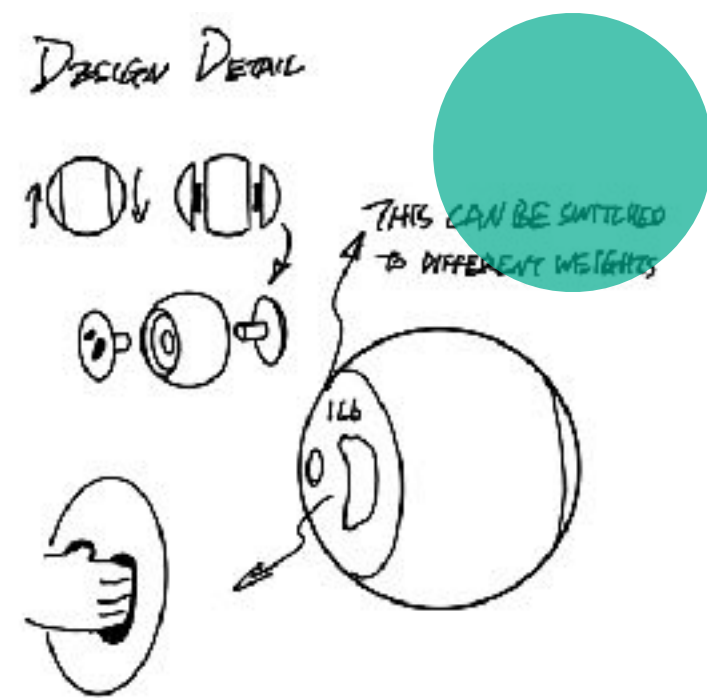

MULTI-PURPOSE TOOL

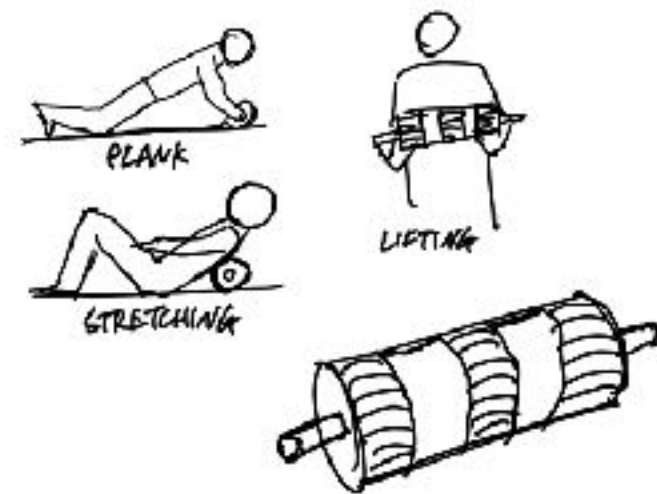

WITH A TV OR A TABLET, YOU CAN GET PROFESSIONAL GUIDANCE FROM A COACH

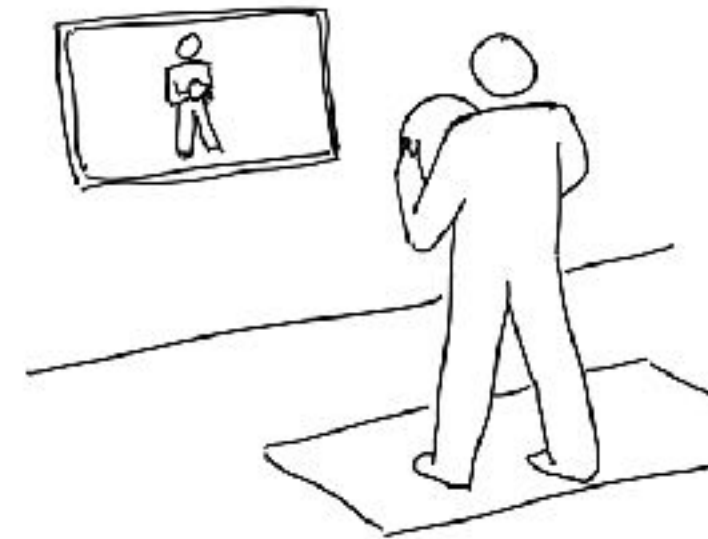

MULTI-PURPOSE TOOL

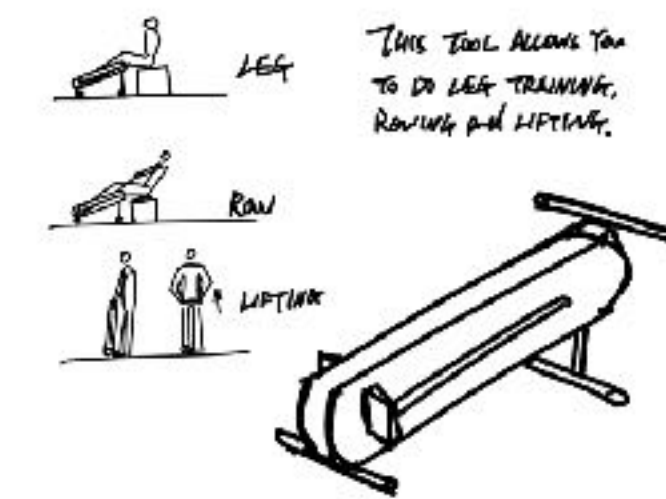

STAY BALANCE ON THE PLATFORM

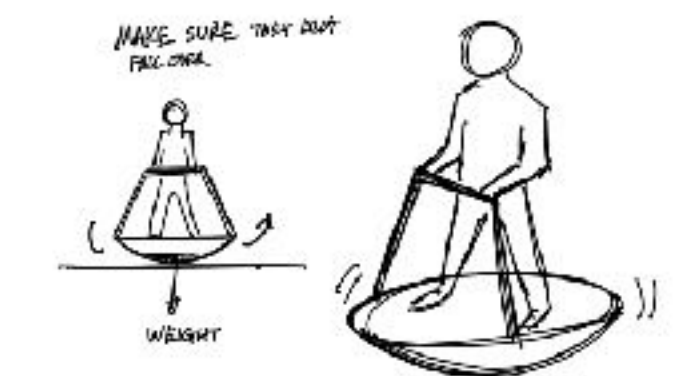

ROTATING PLATE FOR TRAINING

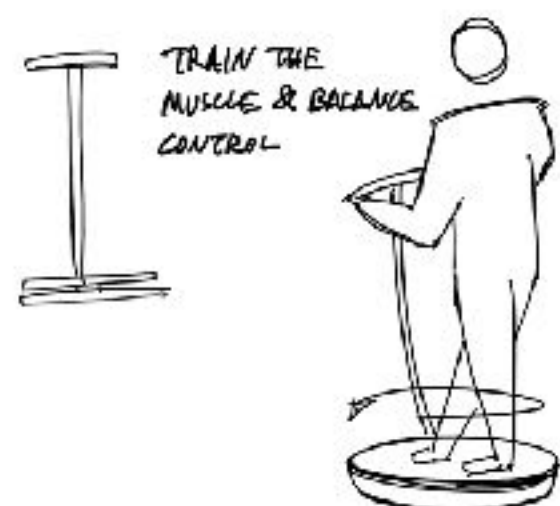

BALANCE PATH

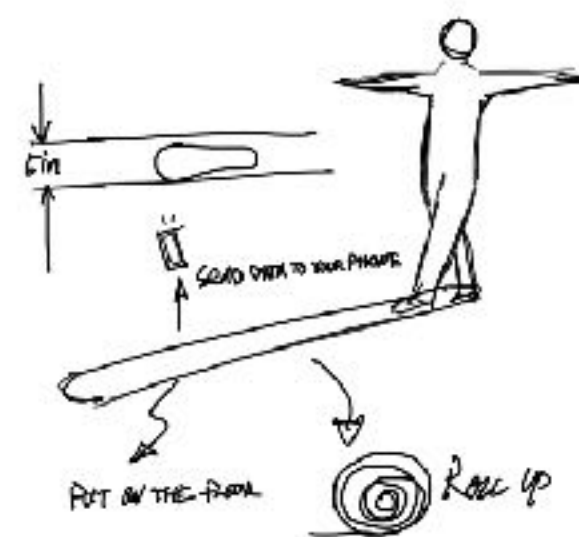

MULTI-PURPOSE FITNESS BALL

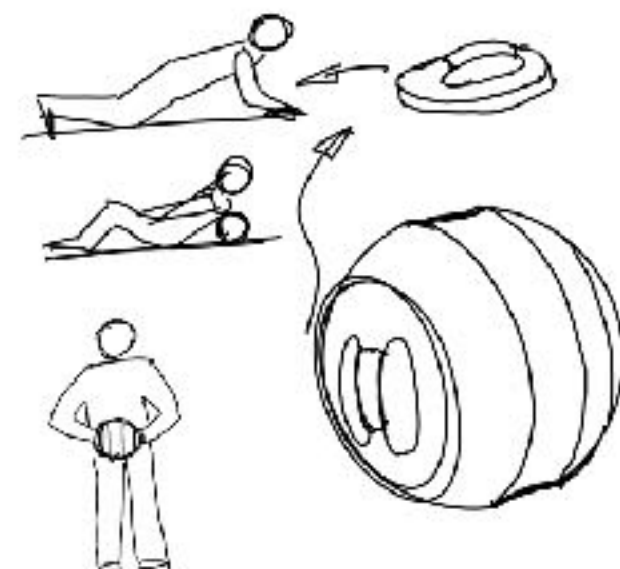

LEG STRENGTH TRAINING STOOL

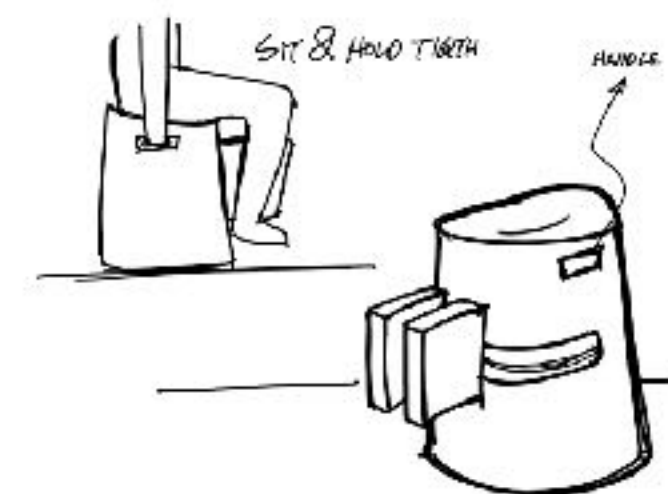

BALANCE STOOL

You can exercise while not exercising

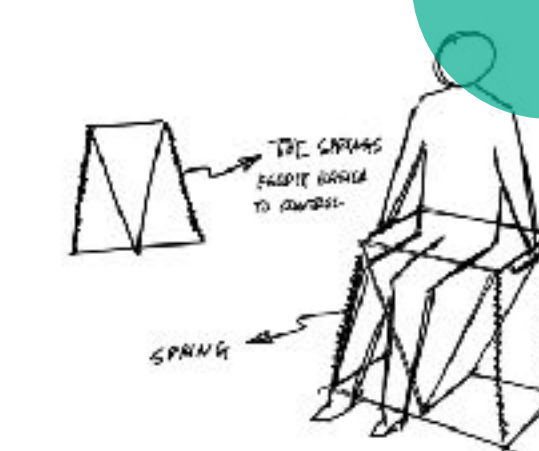

A HEAD BAND WITH 3D CAMERA THAT HELPS WITH YOUR TRAINING

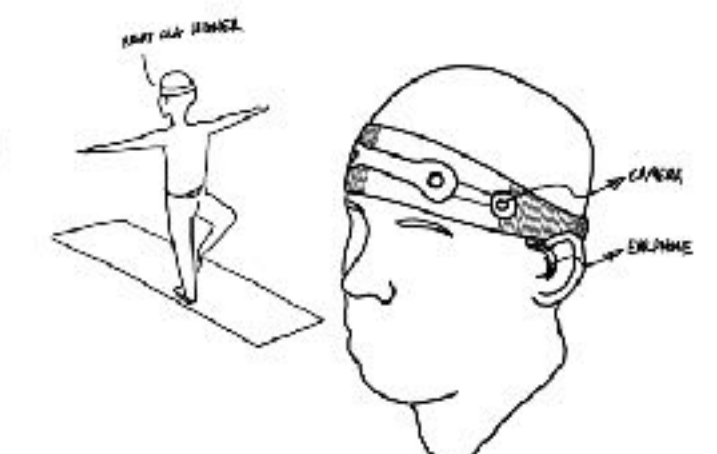

# Ideation screening

DESIGN DETAIL

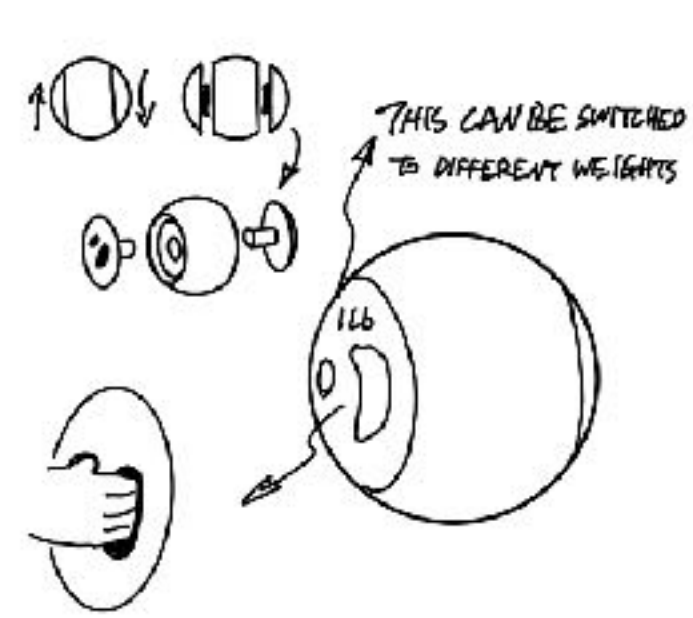

DESIGN DETAIL

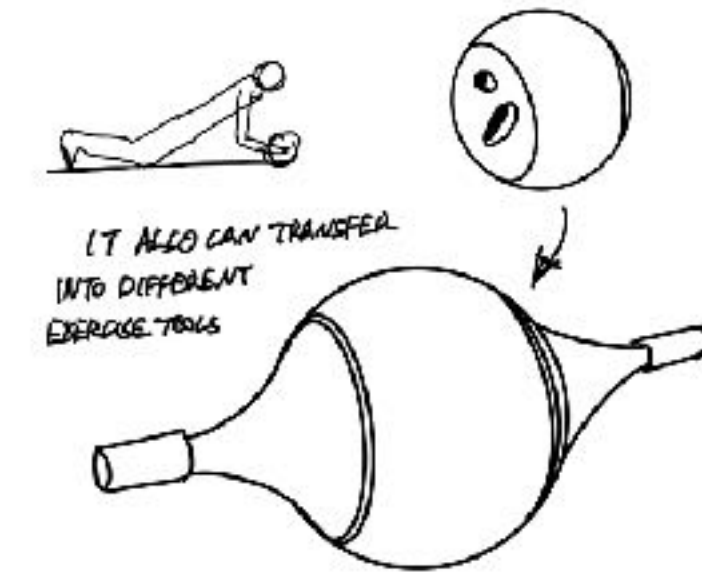

BALANCE PATH

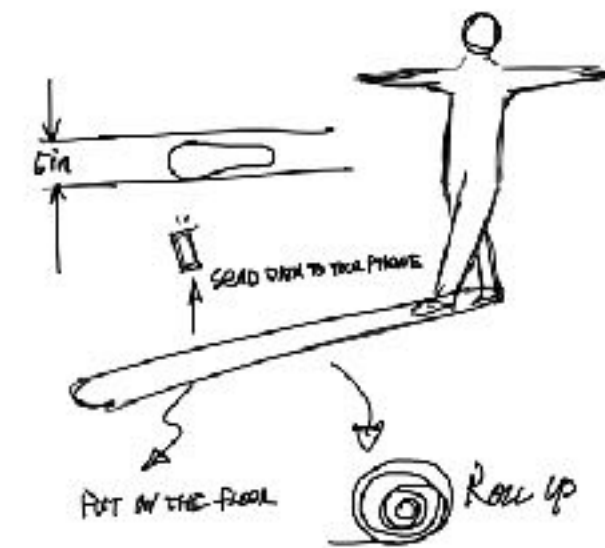

BALANCE GAME

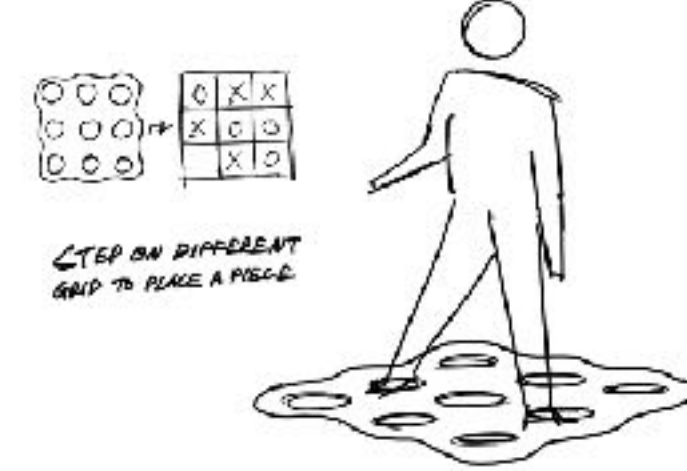

LEG STRENGTH TRAINING

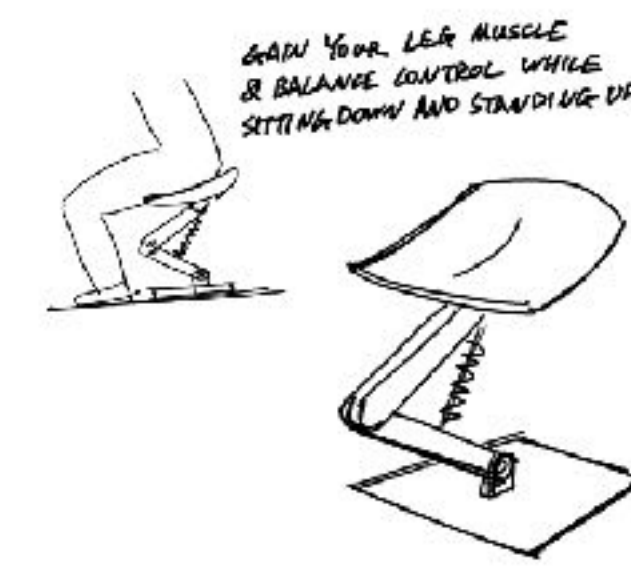

BALANCE STOOL

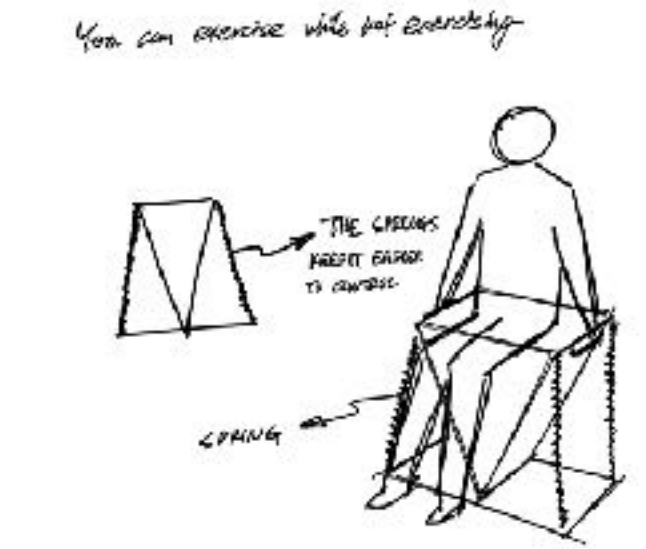

## A smart training ball

that can accomplish different exercises.



## A smart mat

that helps seniors train their balance ability safely.



## A training chair

that specially designed to give seniors a solid base to workout.



# Ideation development

The training ball

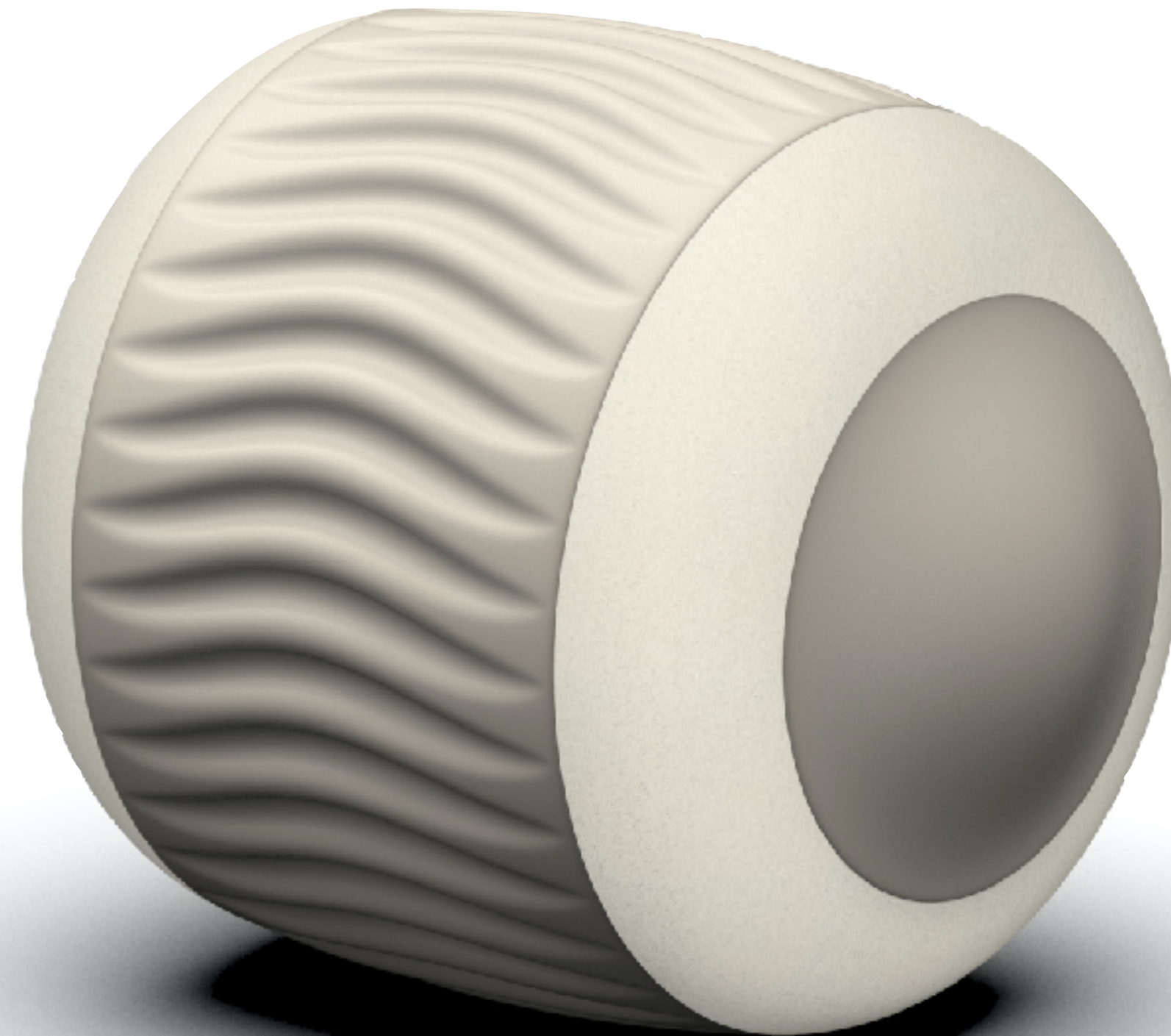

# Ideation development

## The training ball

DESIGN DETAILS

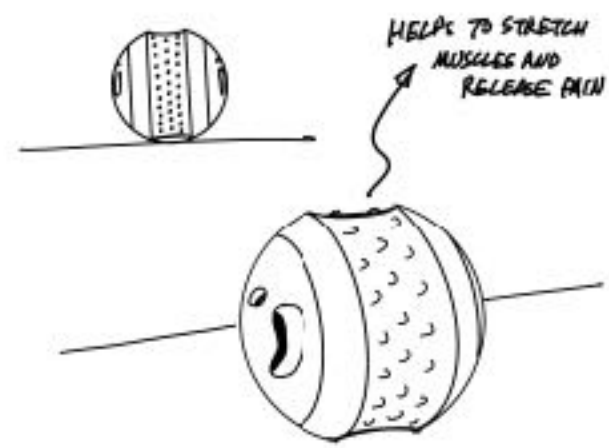

BODY TWISTING EXERCISE

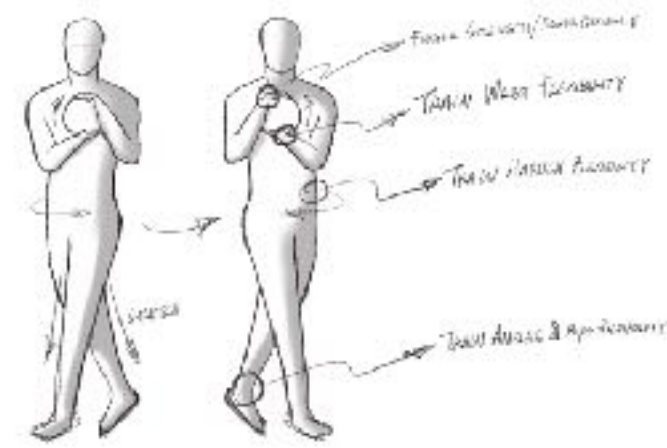

RUSSIAN TWIST

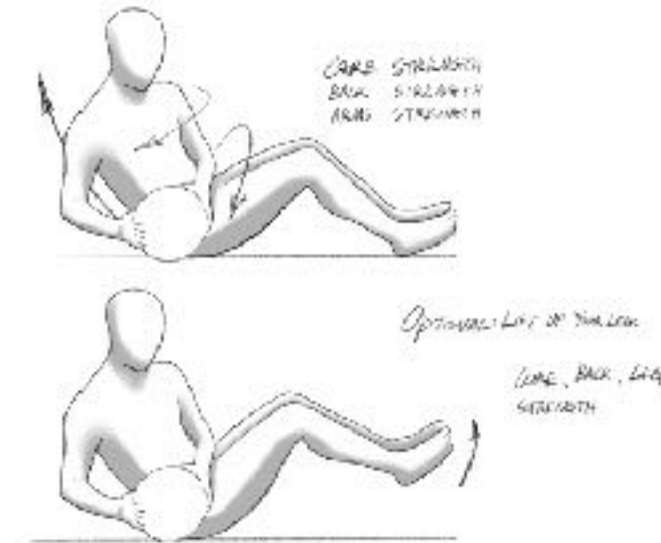

LUNGS AND SHOULDERS

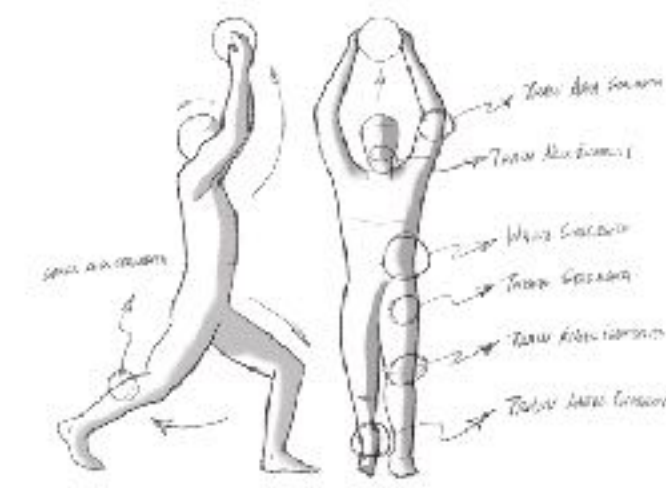

FITNESS GAME BALL



MULTI-PURPOSE TOOL

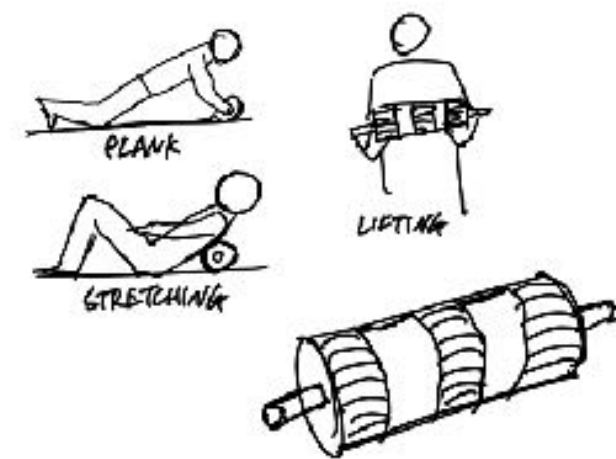

MULTI-PURPOSE FITNESS BALL

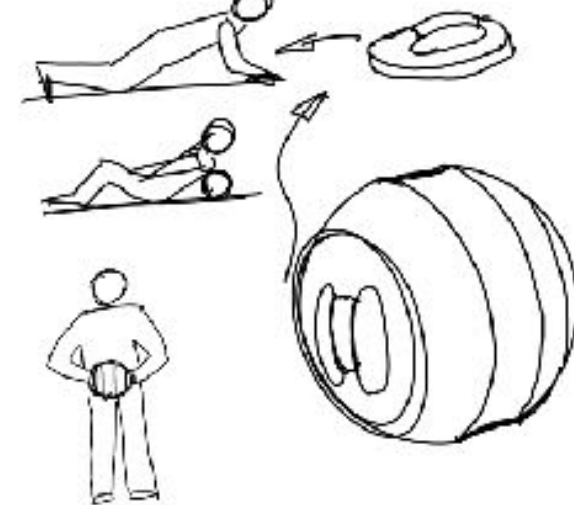

LIFTING

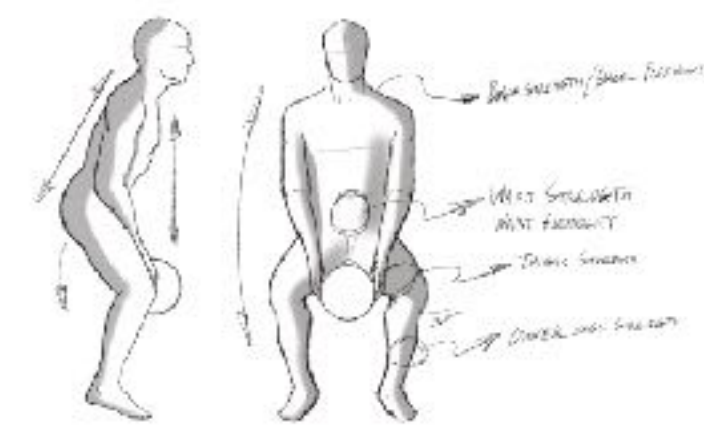

MARK TIME EXERCISE

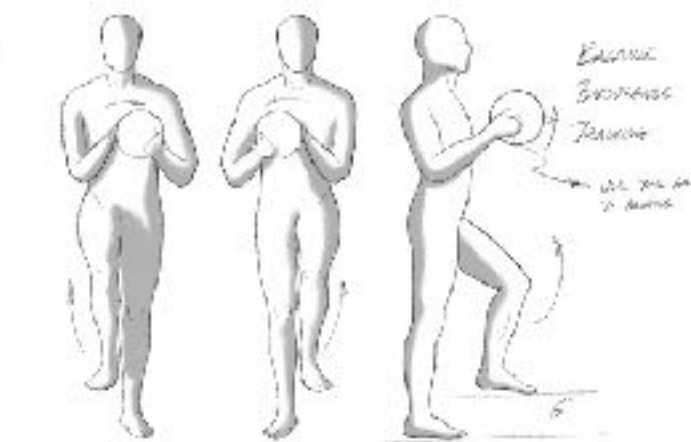

LEGS & ANKLES STRETCH

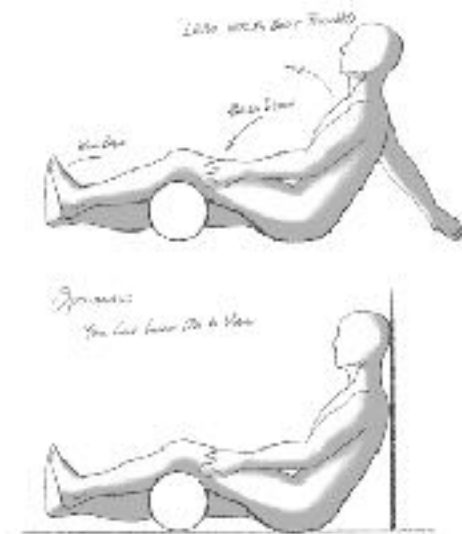

DESIGN DETAIL

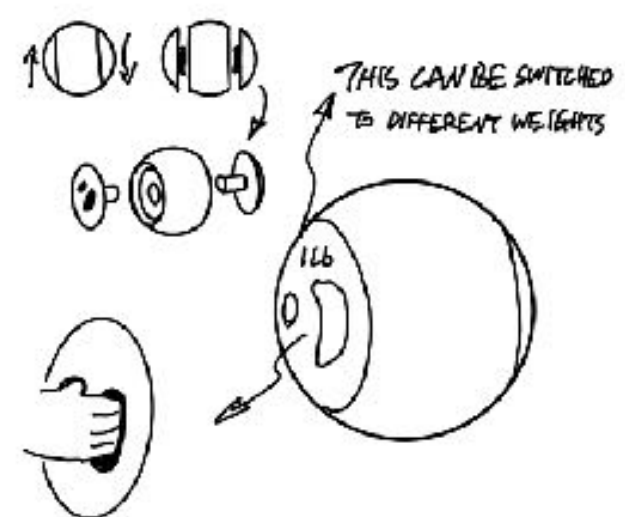

DESIGN DETAIL

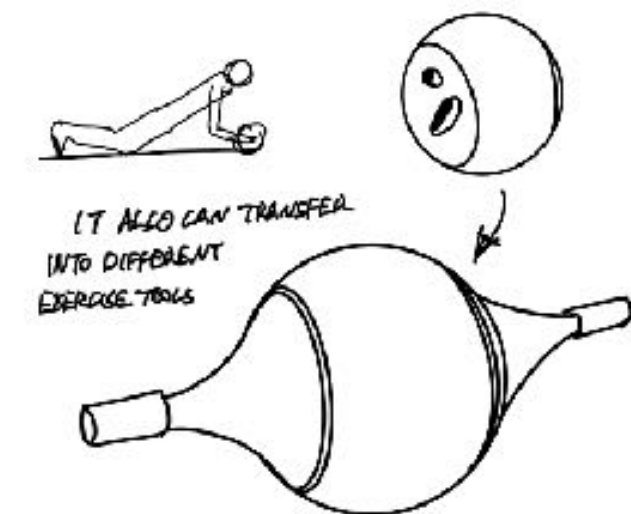

WITH A TV OR A TABLET, YOU CAN GET PROFESSIONAL GUIDANCE FROM A COACH

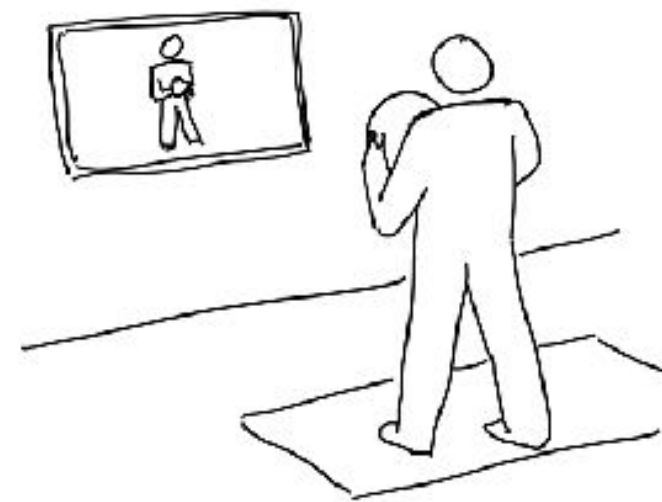

CARDIO

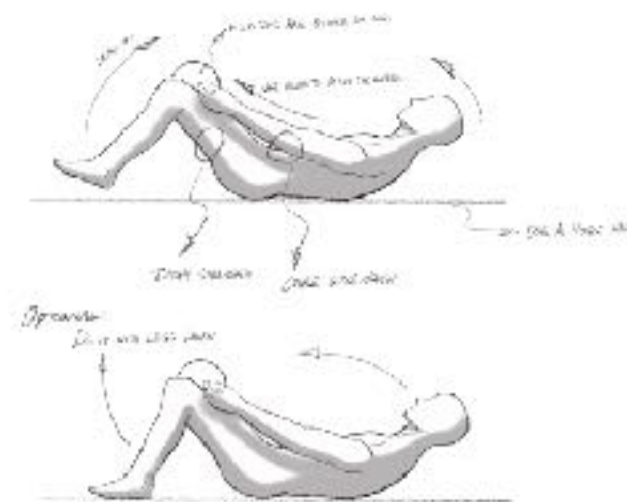

BODY TWIST

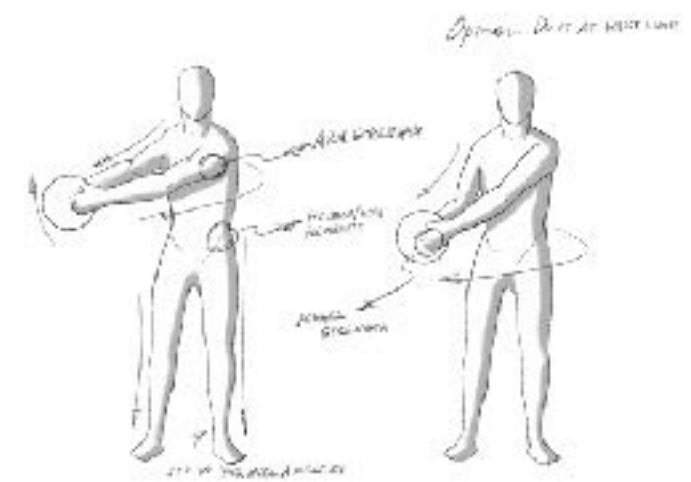

TORSO STRETCH

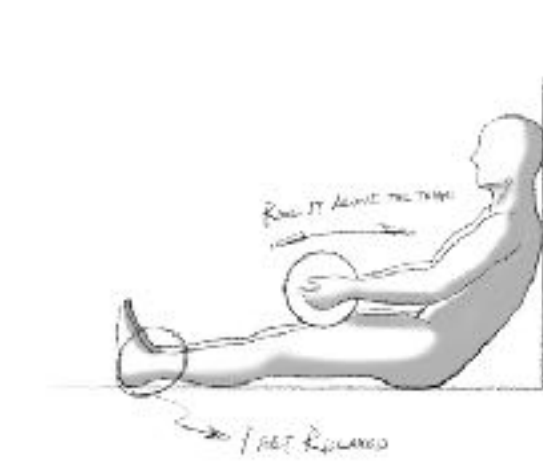

# Ideation development

## The training ball

### Primary Mode

### Advanced Mode

#### Ab Roller

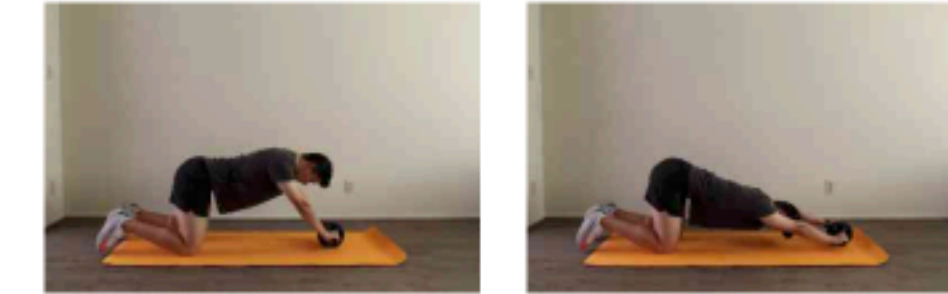
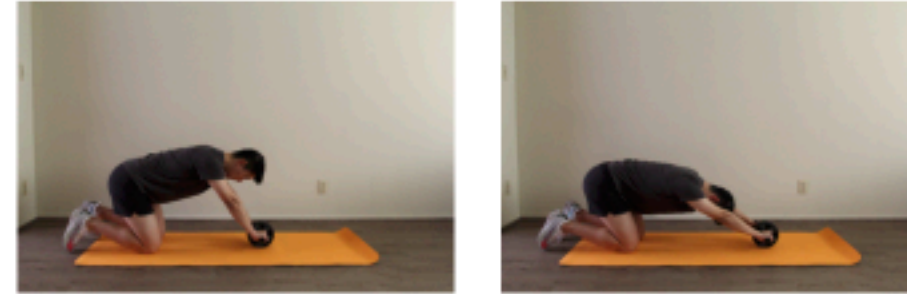
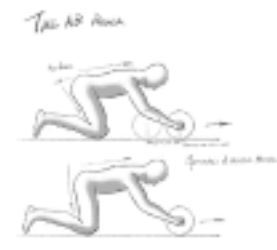

#### Russian Twisting

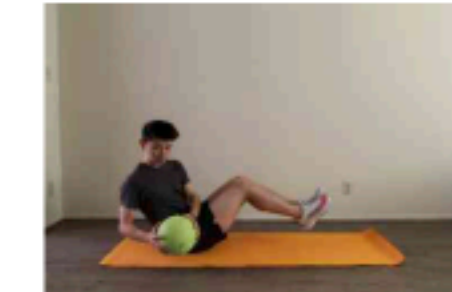

#### Upper Body Twisting

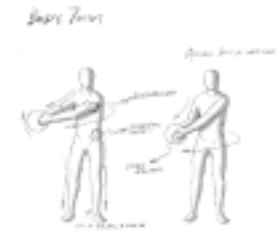

#### Crunches

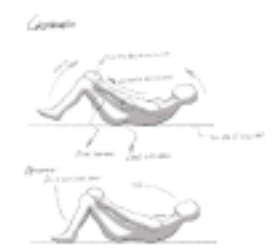

#### Vertical Lifting

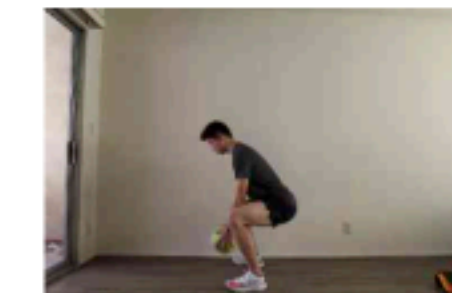
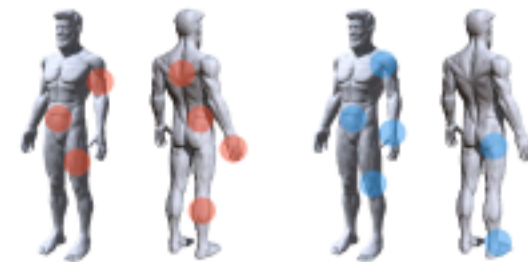

# Ideation development

## The training ball

### Primary Mode

### Advanced Mode

#### Mark Time Exercise

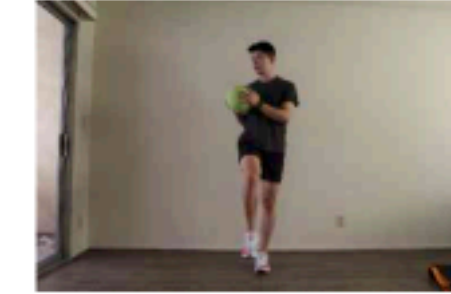
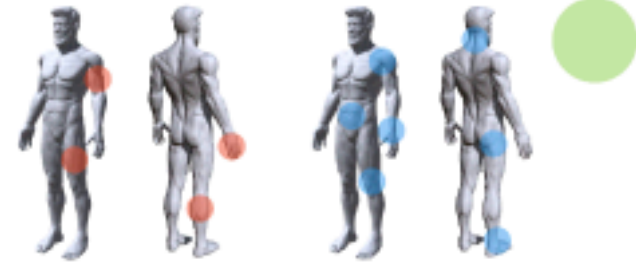

#### Lunge Head Exercise

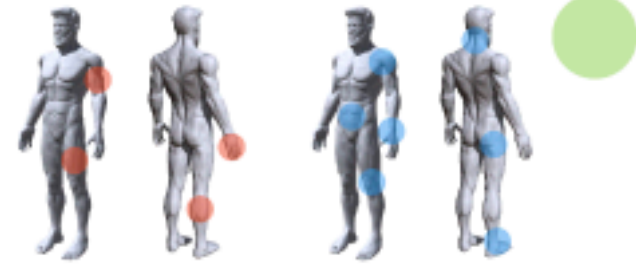

#### Body Twisting

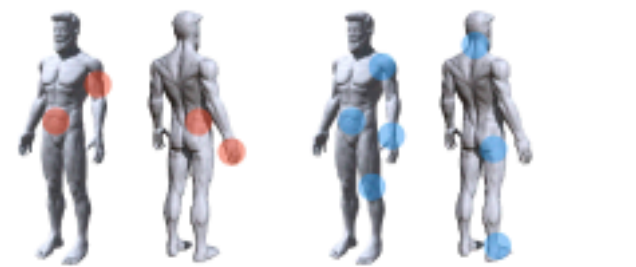

#### Leg Stretching



#### Thigh Stretching

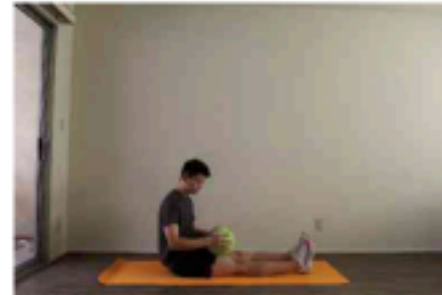
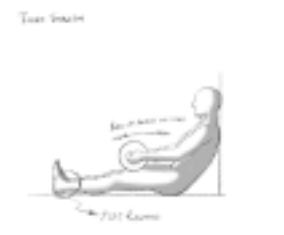

# Ideation development

## The training ball

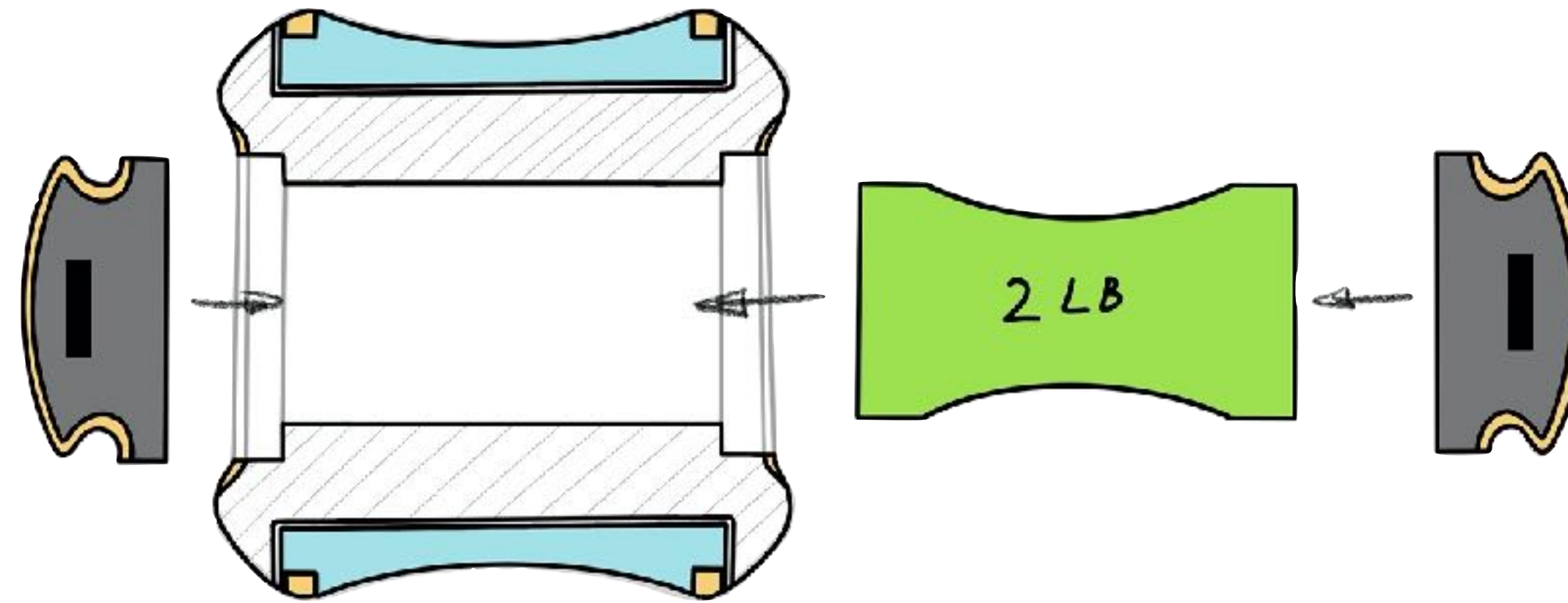
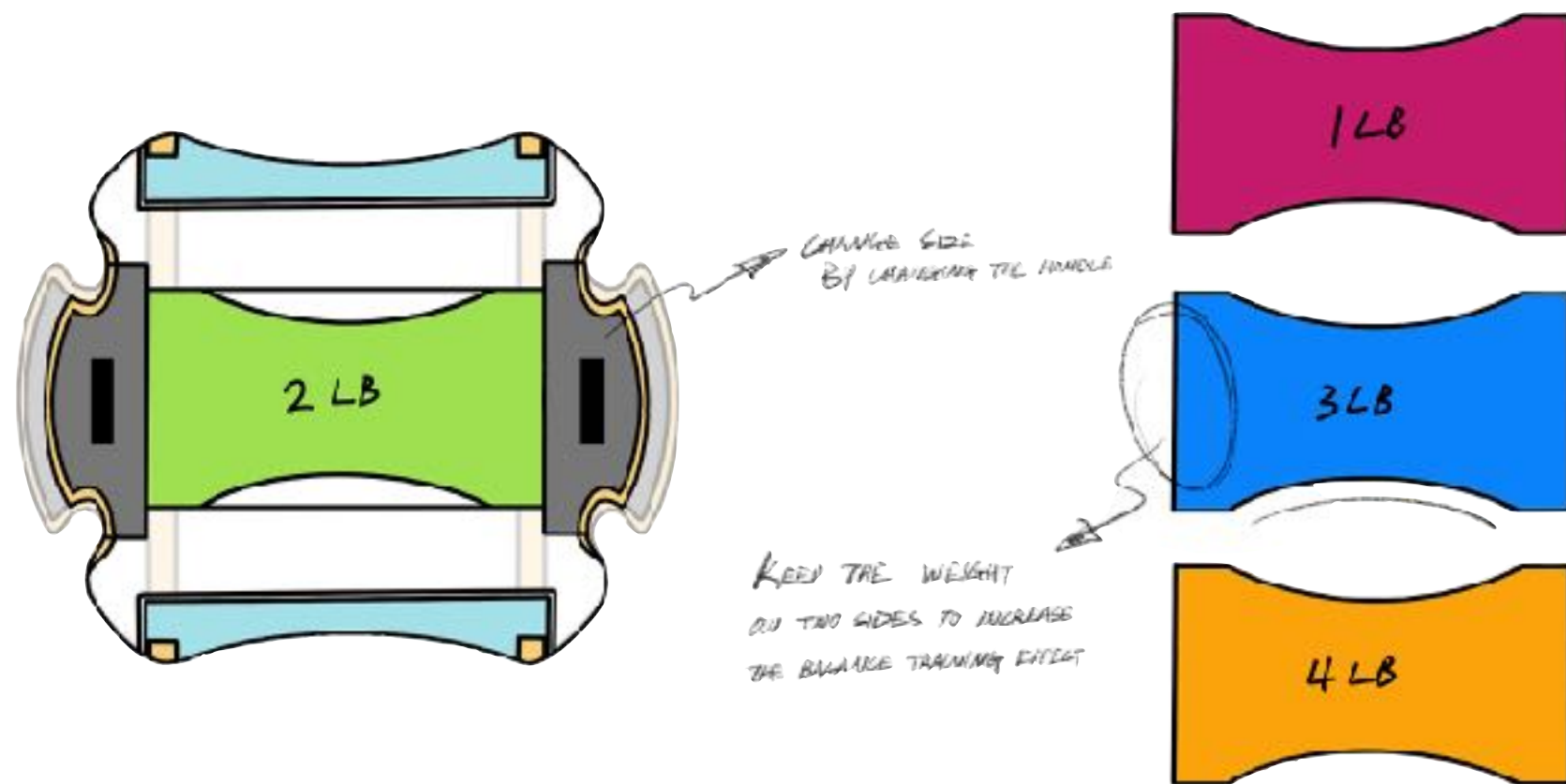
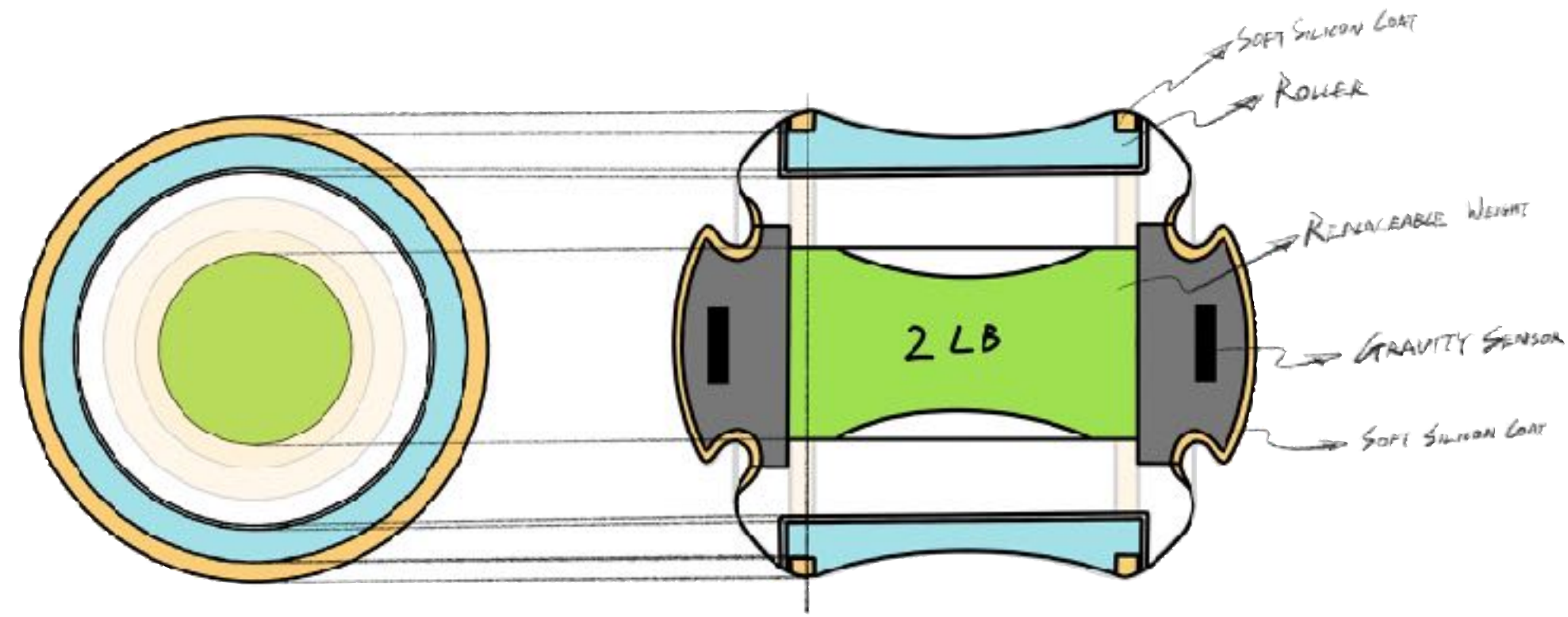
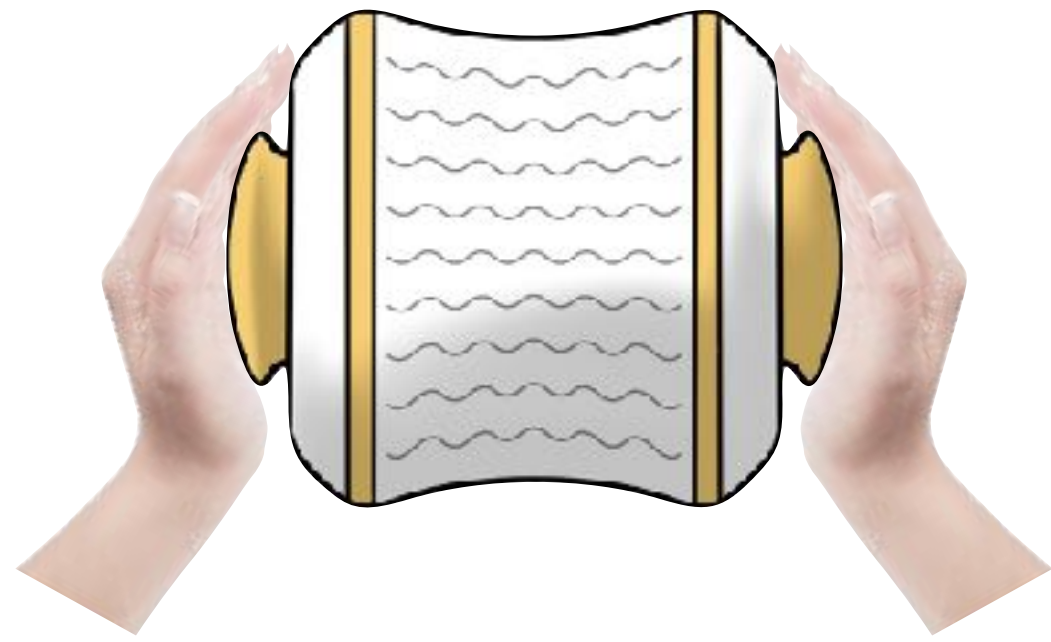

# Ideation development

The training ball

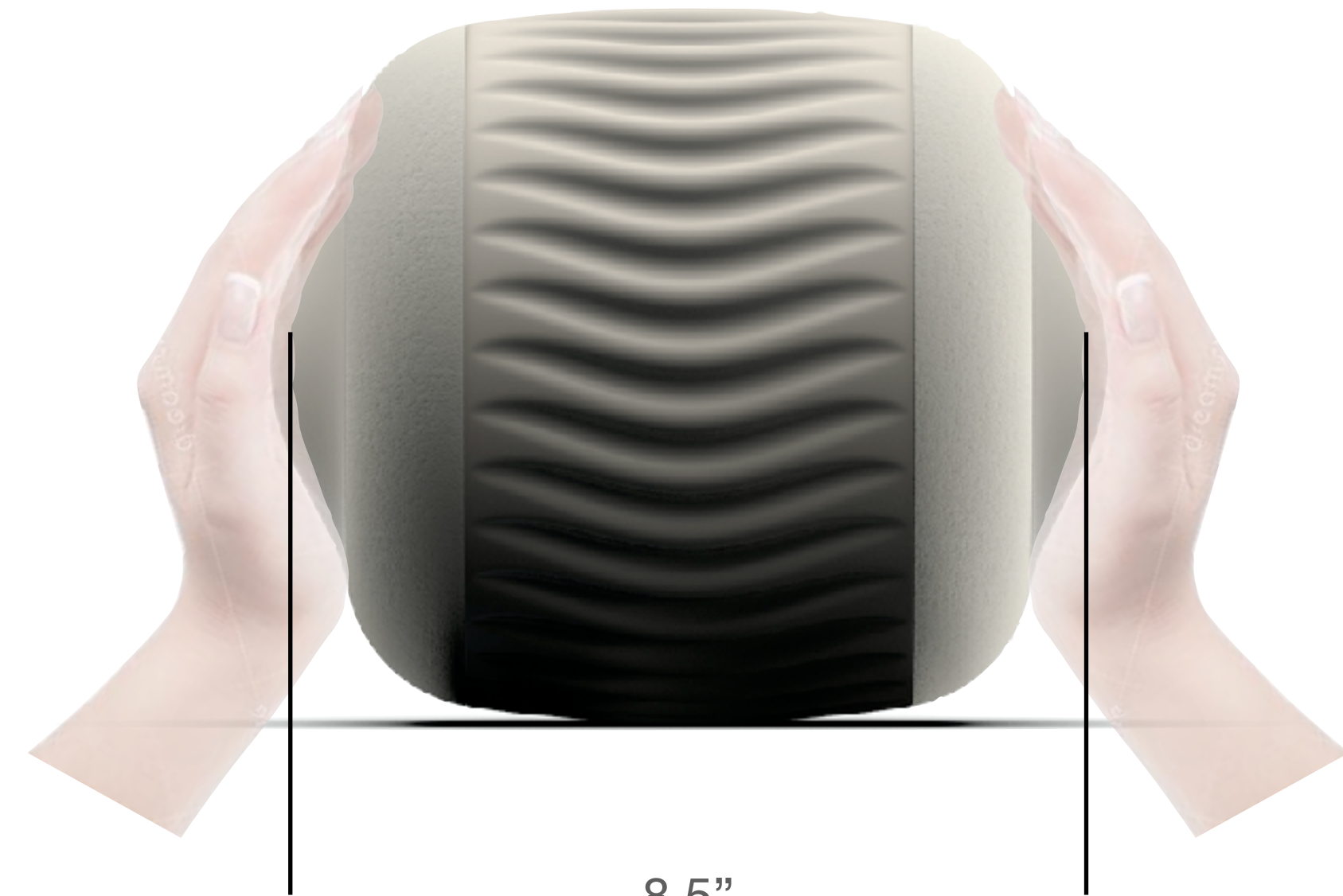
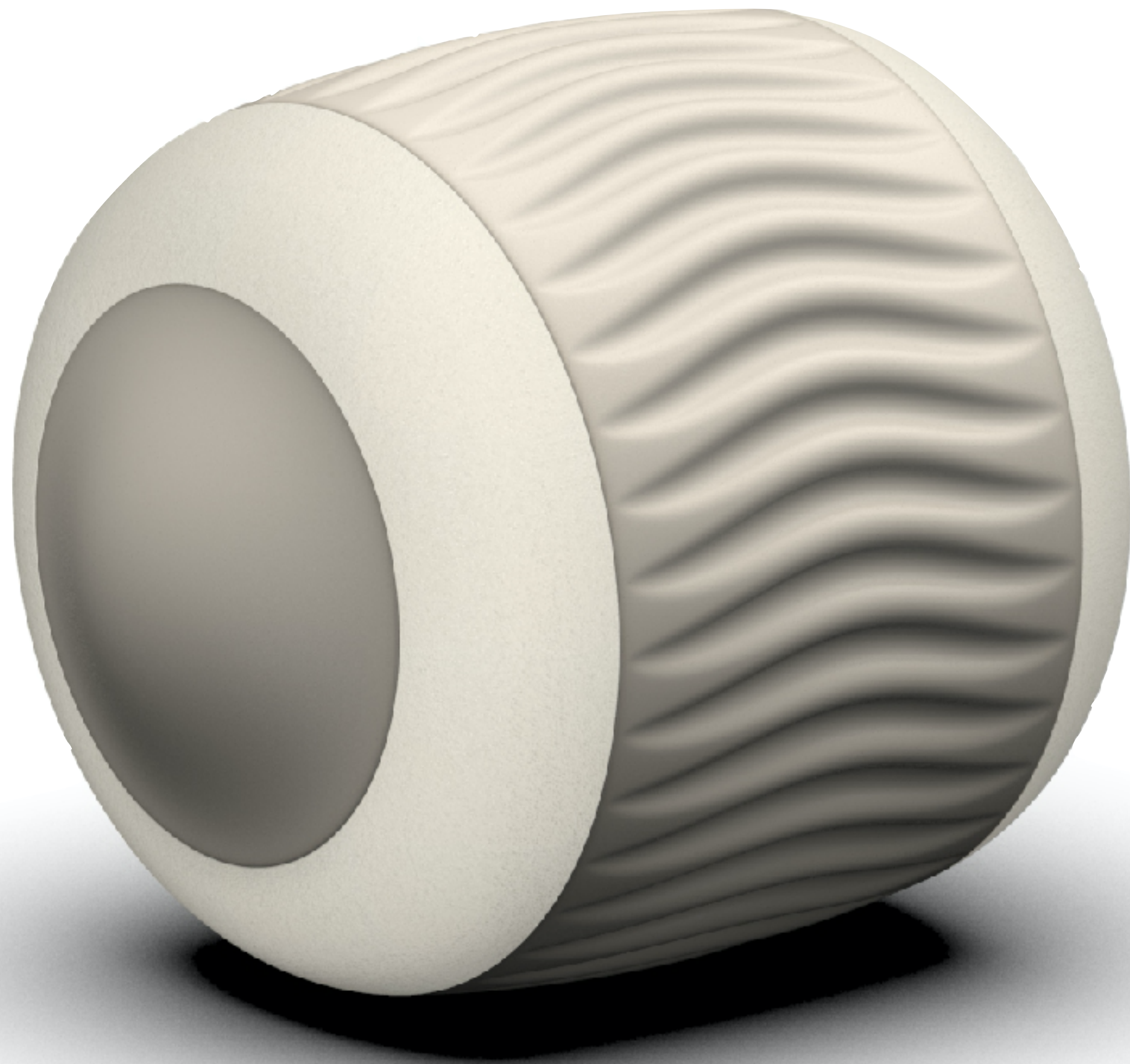

8.5"

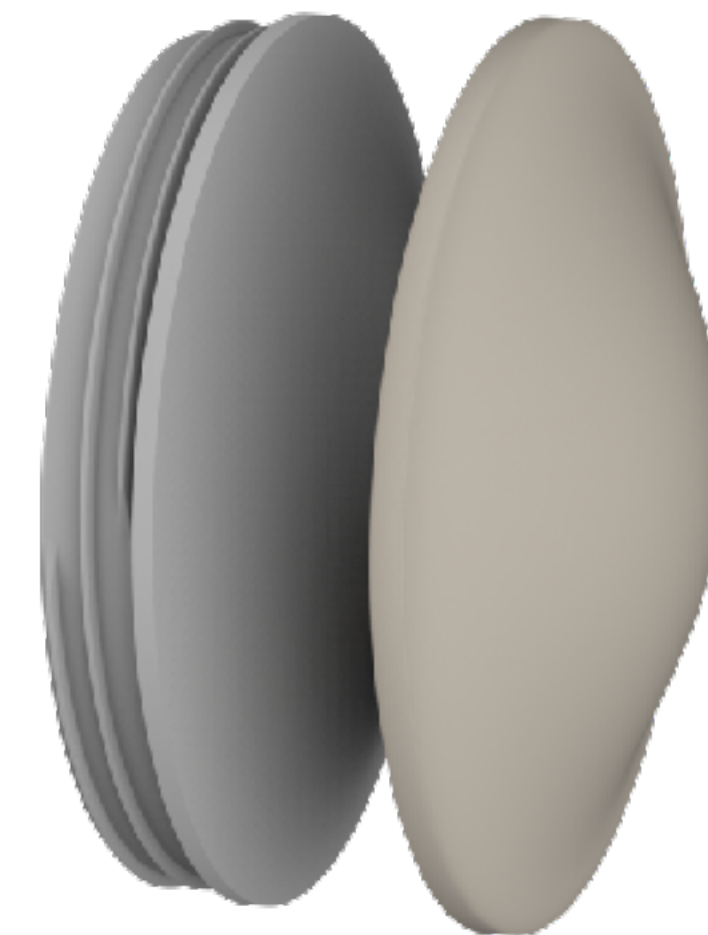

ABS  
Body

Silicone  
Coating

# Ideation development

The training ball

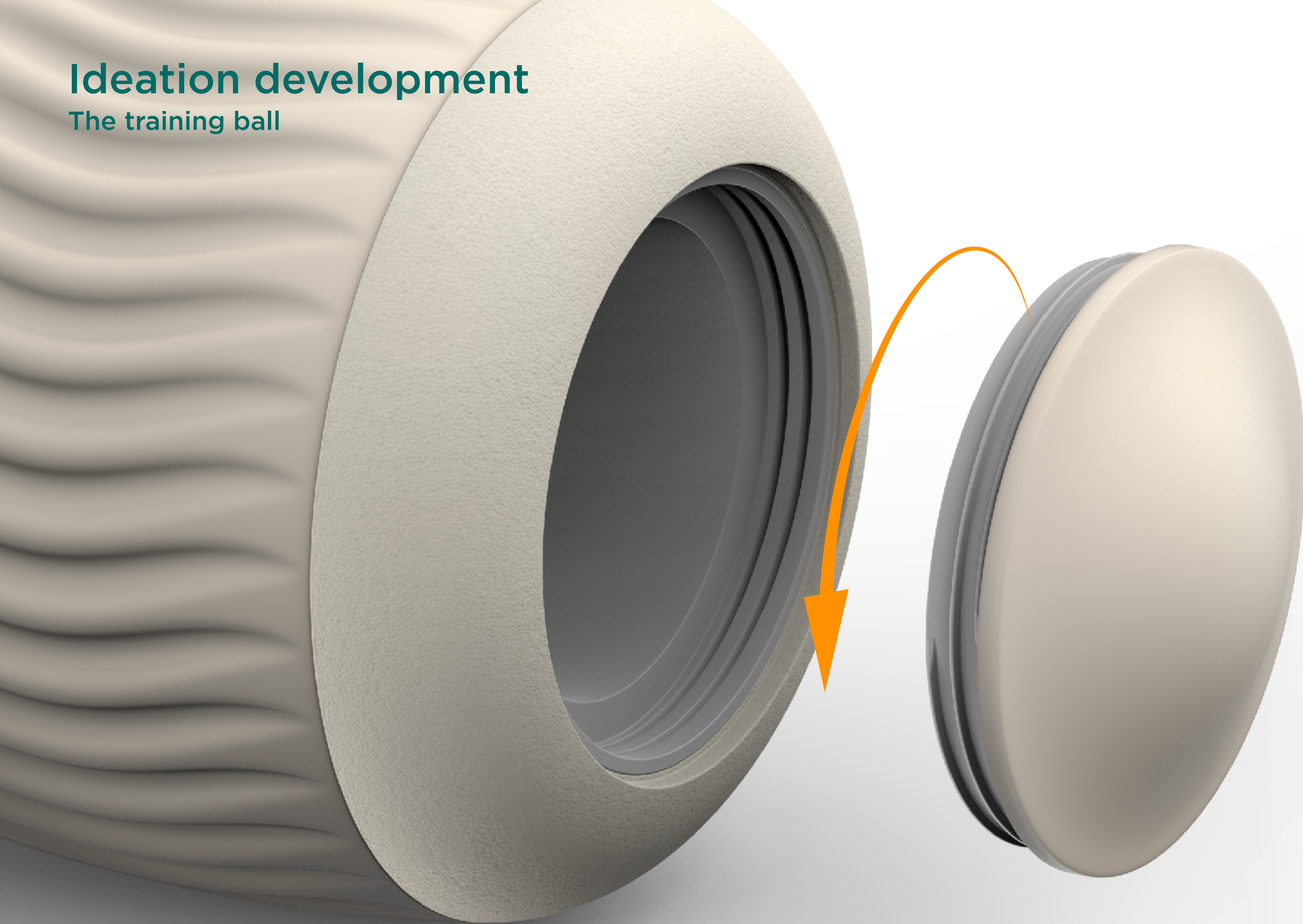

# Ideation development

The training ball

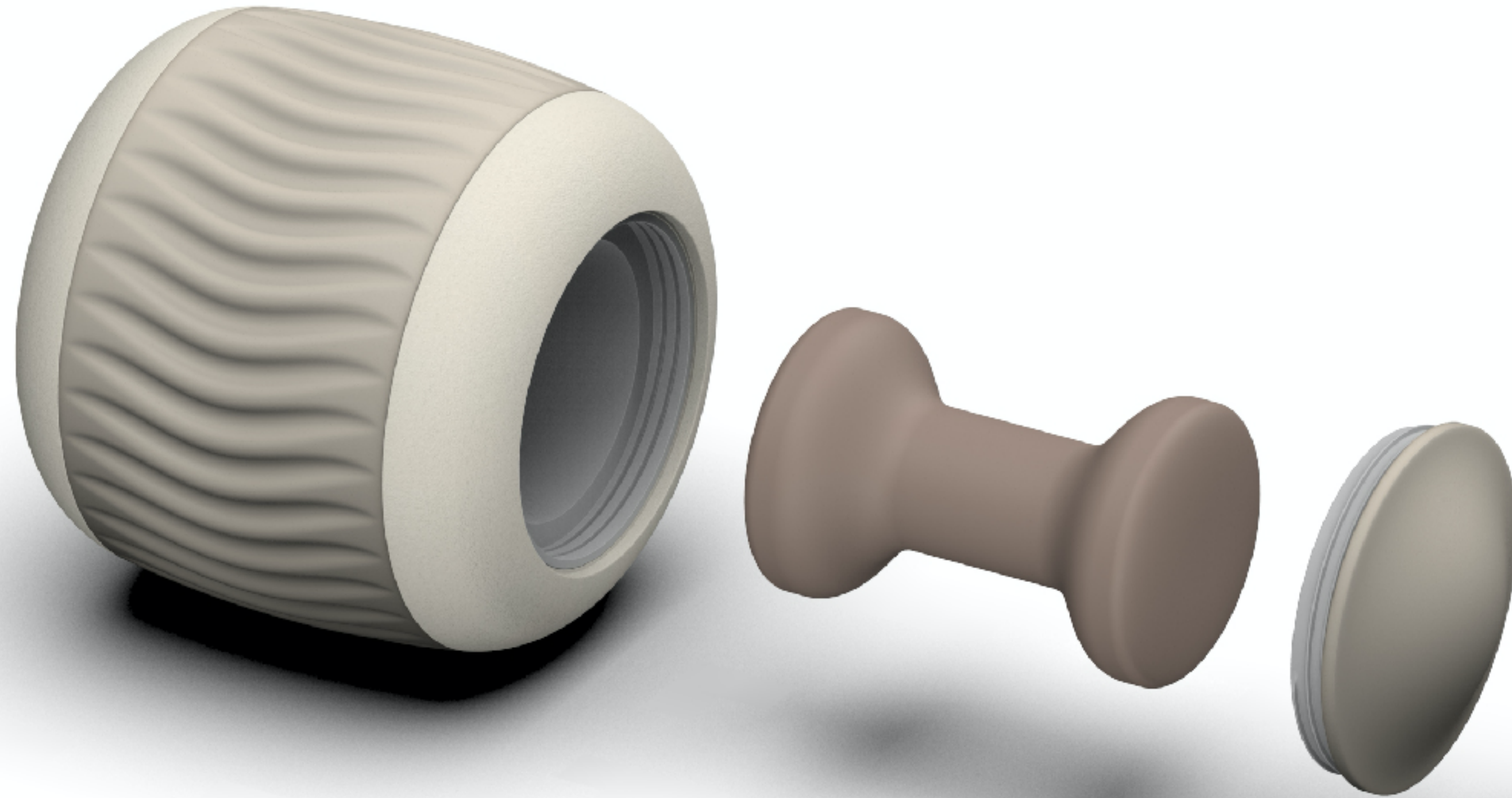

# Ideation development

The training ball

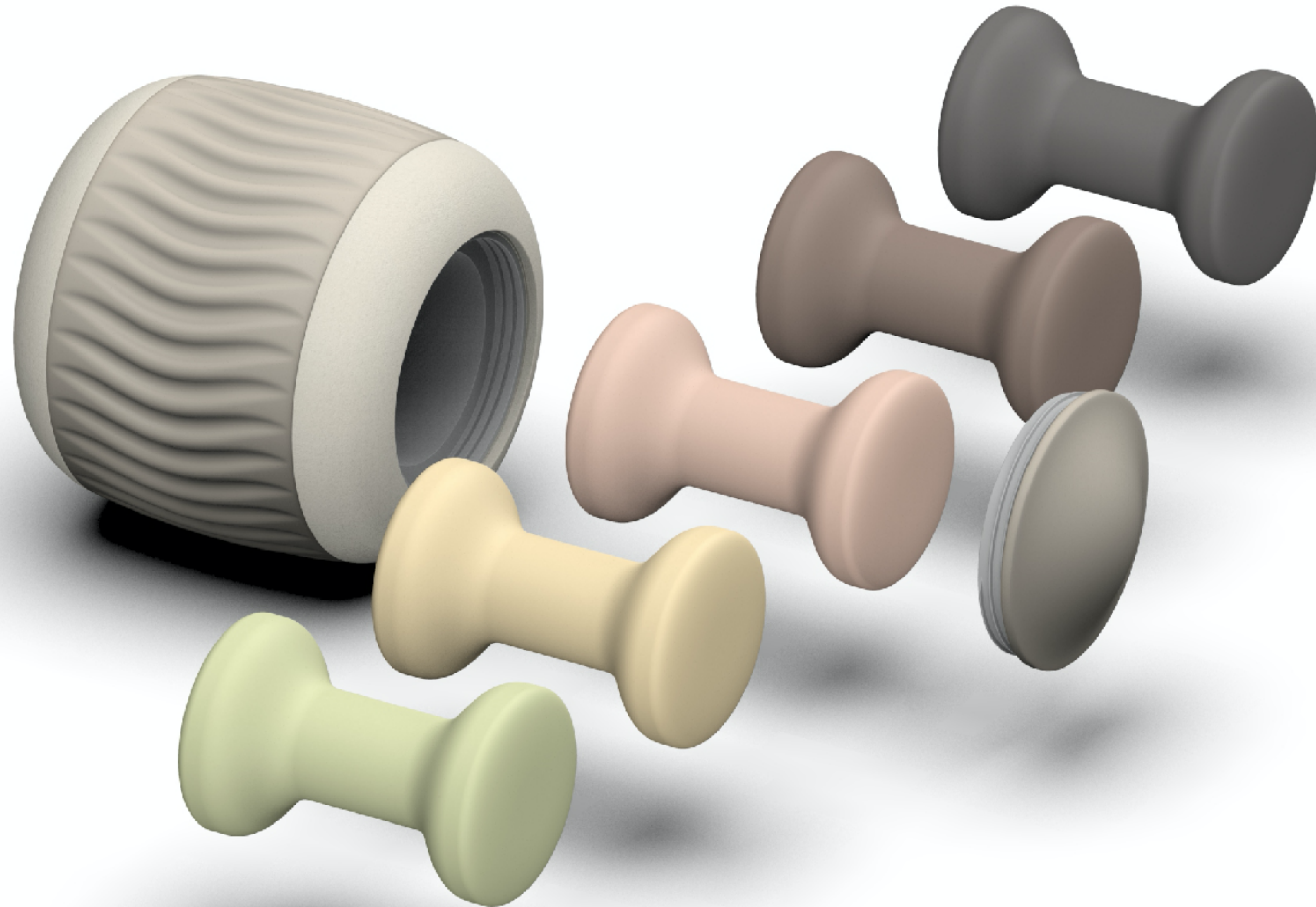

# Ideation development

The training ball

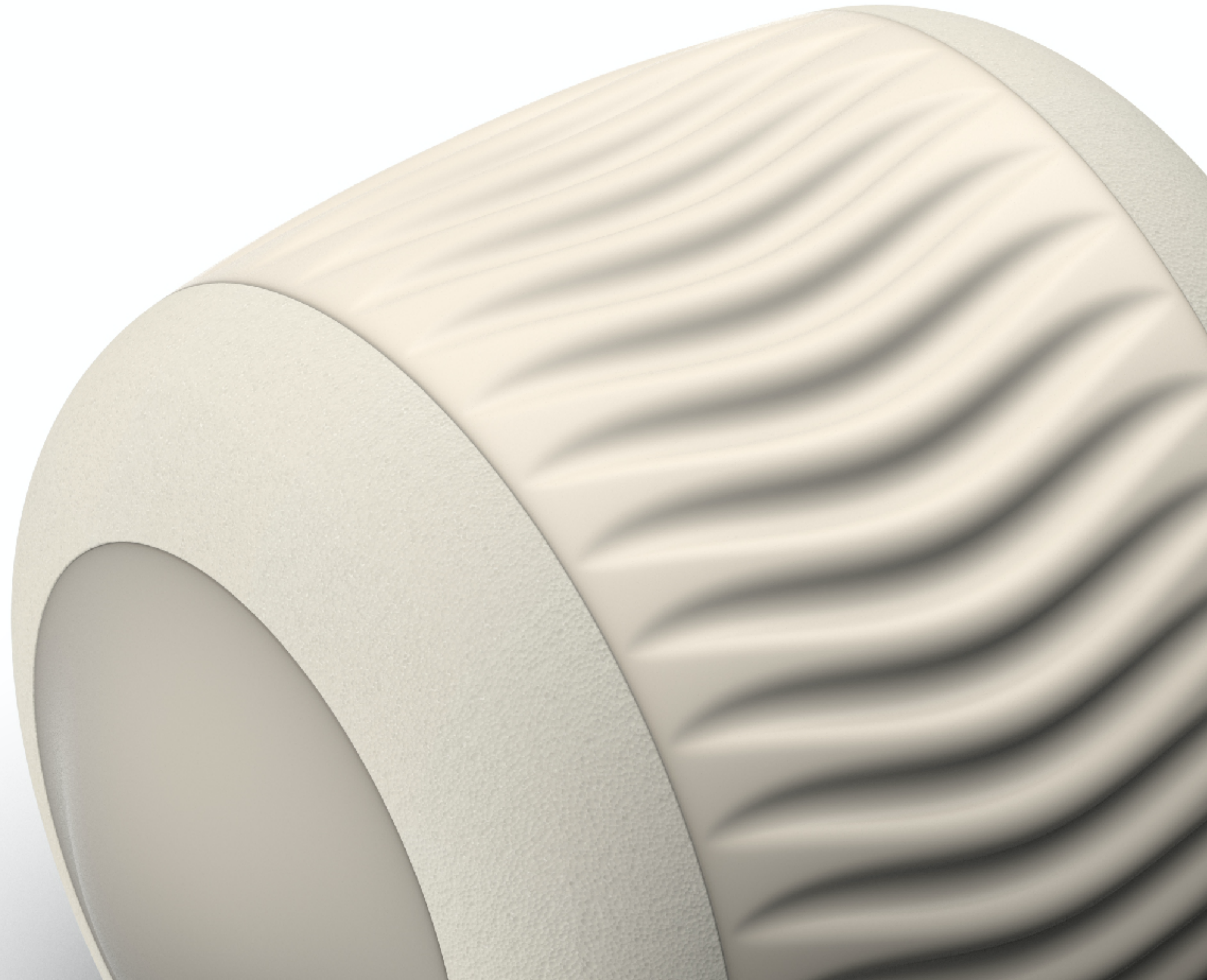

# Ideation development

The training mat

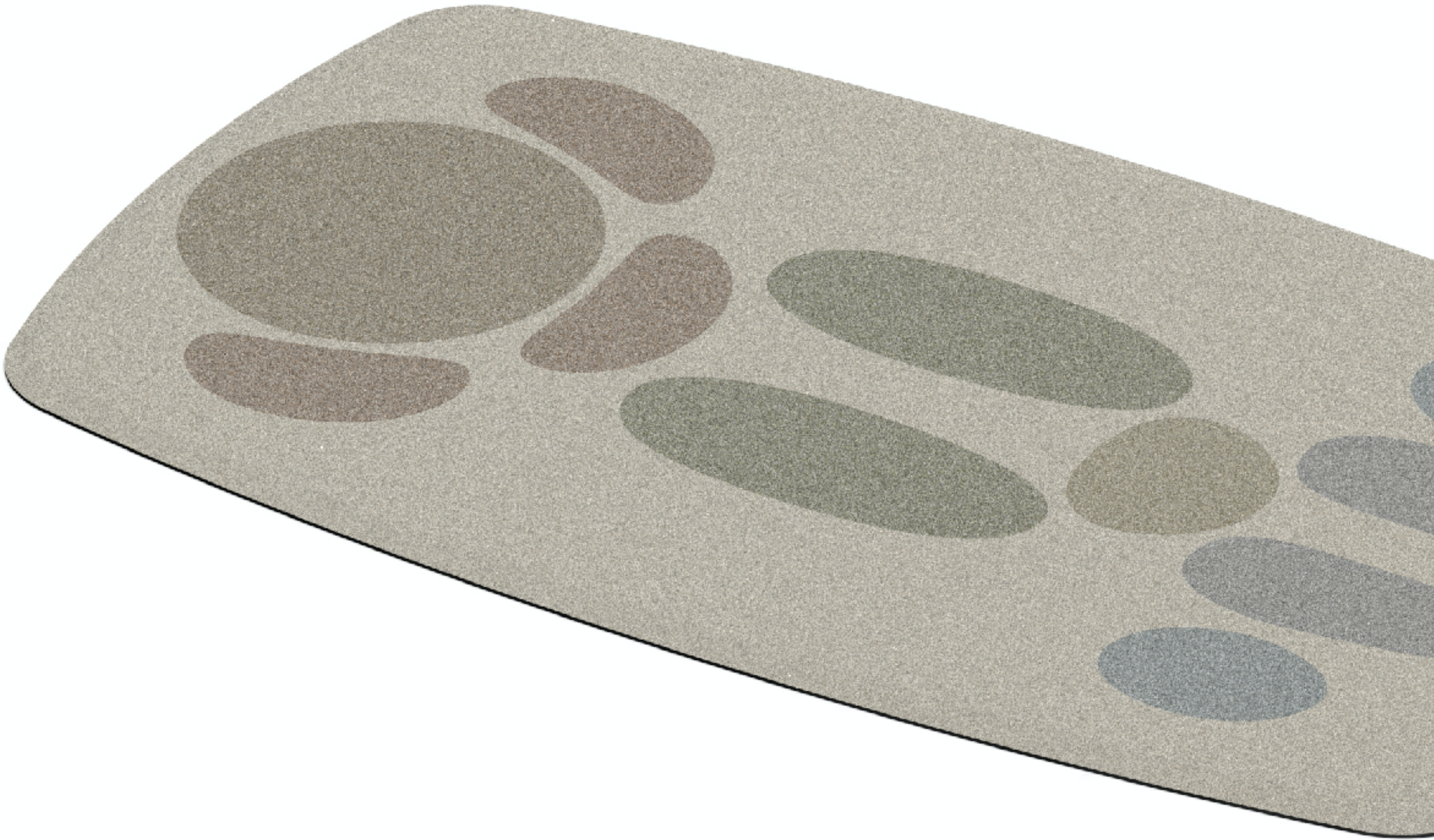

# Ideation development

## The training mat

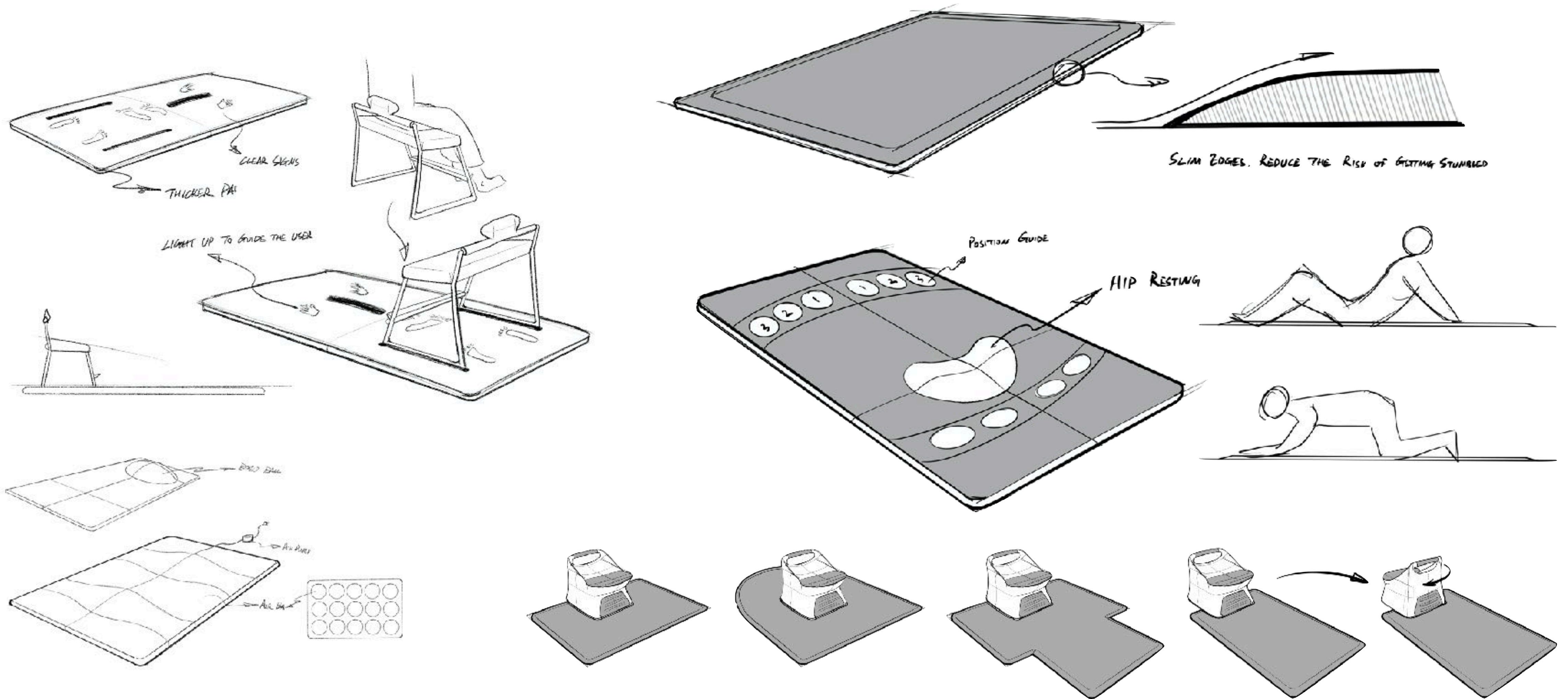

# Ideation development

## The training mat

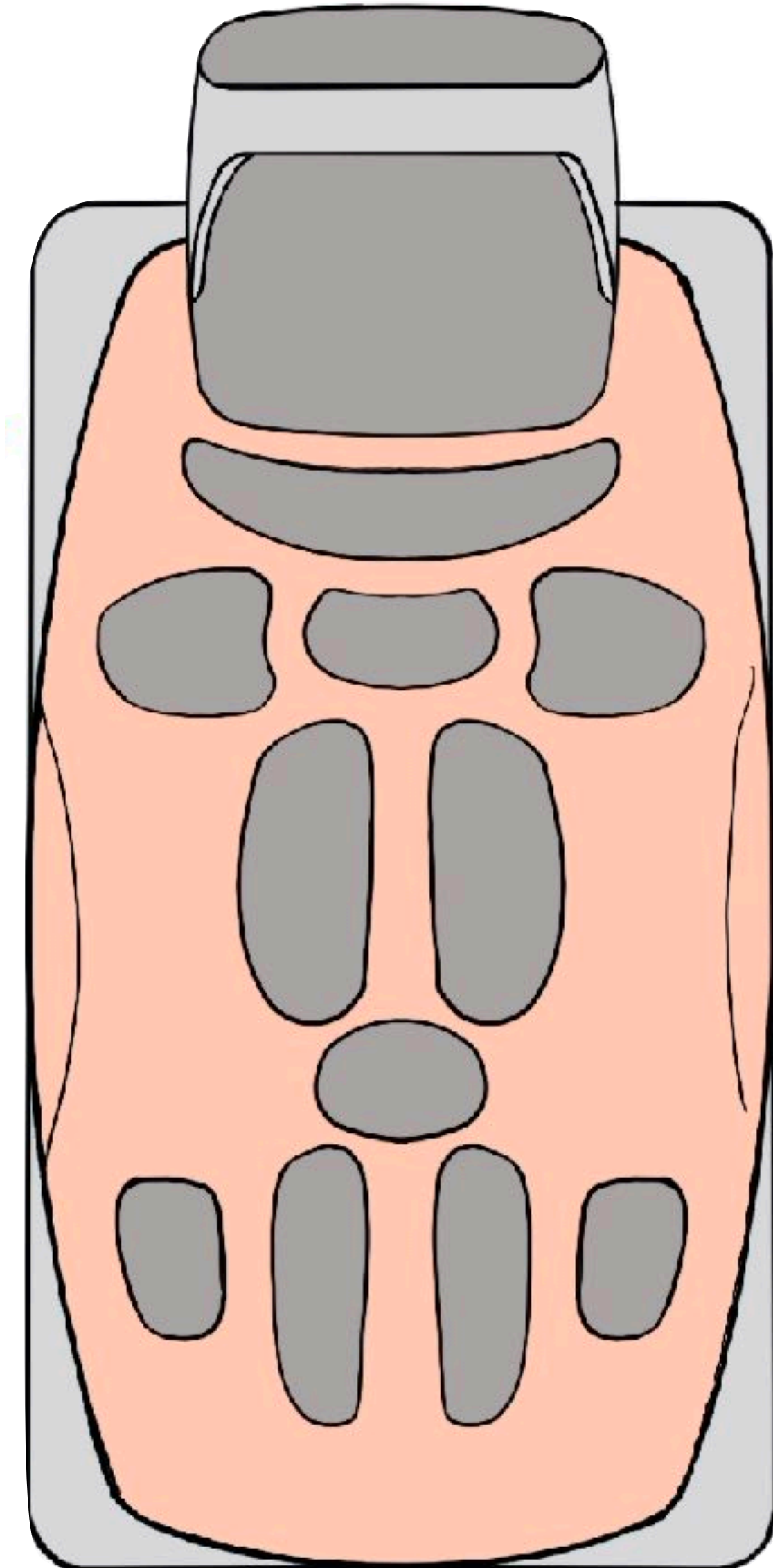
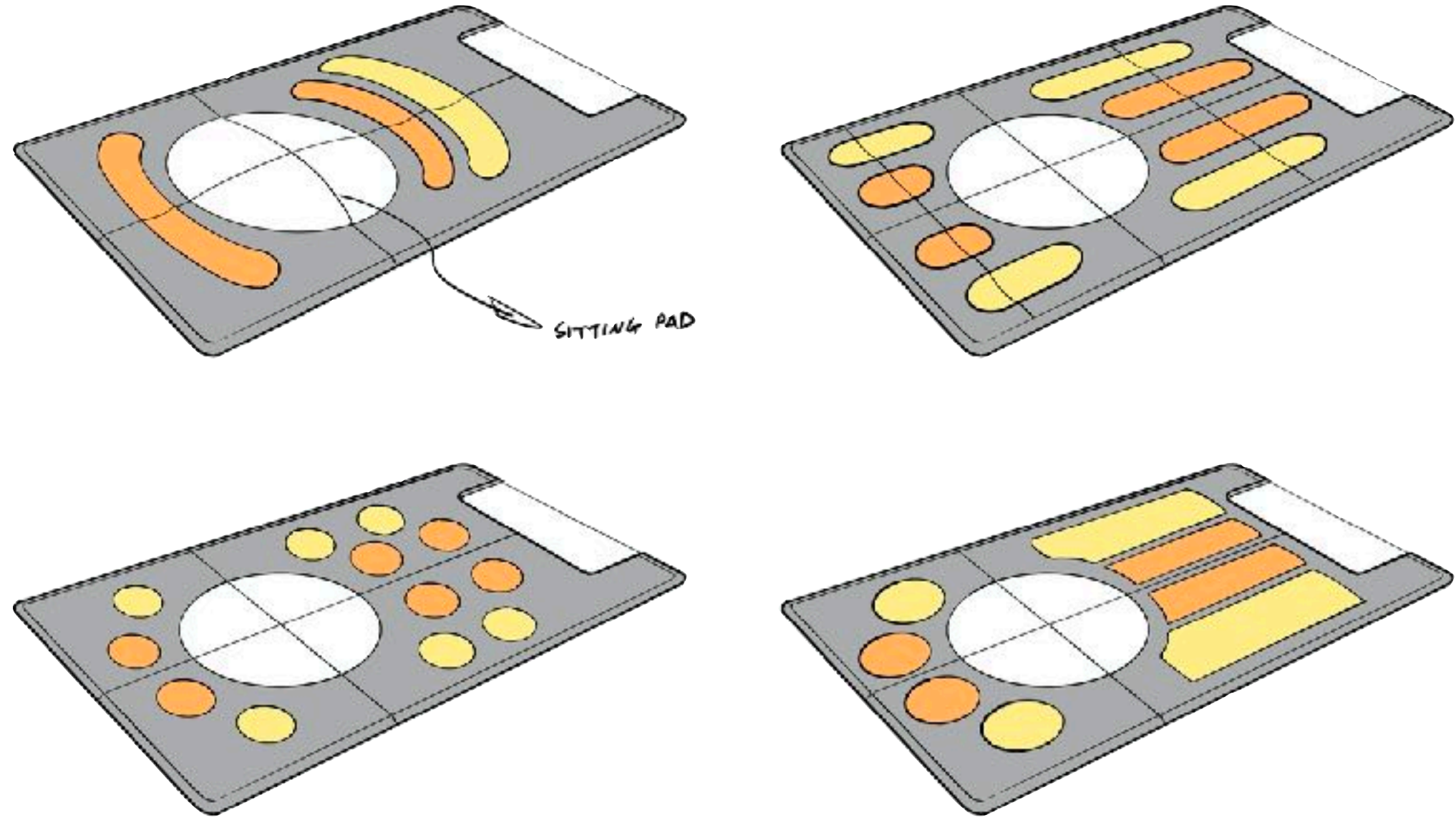

# Ideation development

## The training mat



FIT WITH THE MAT

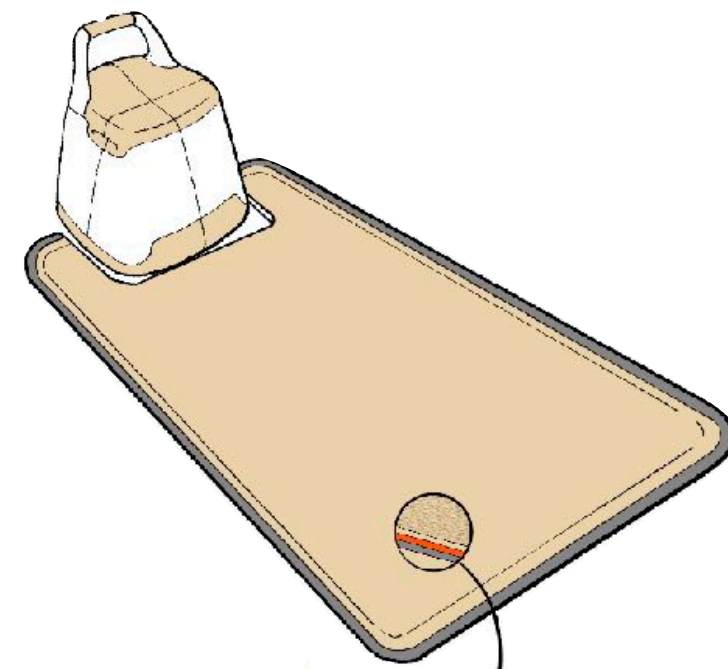

FIT WITH THE MAT

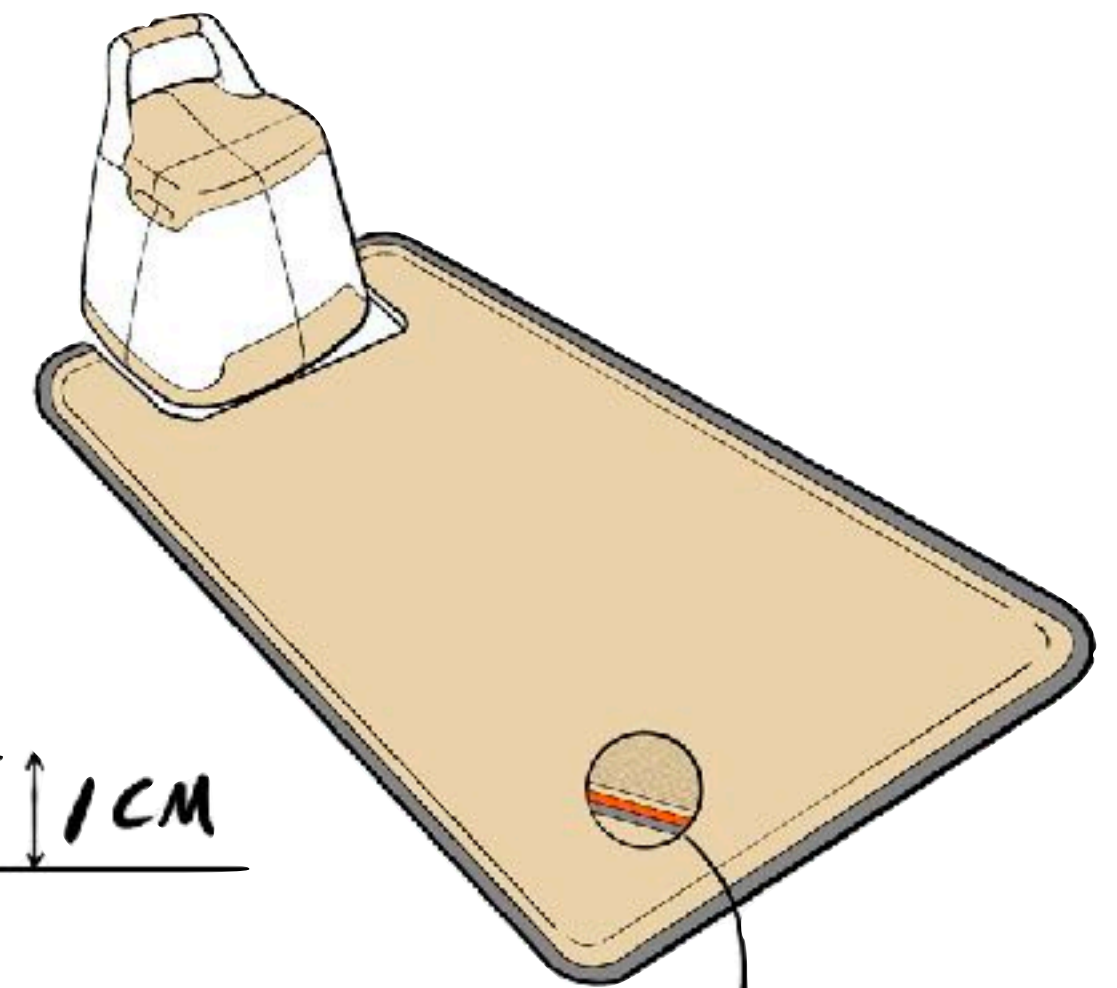

JUTE MAT

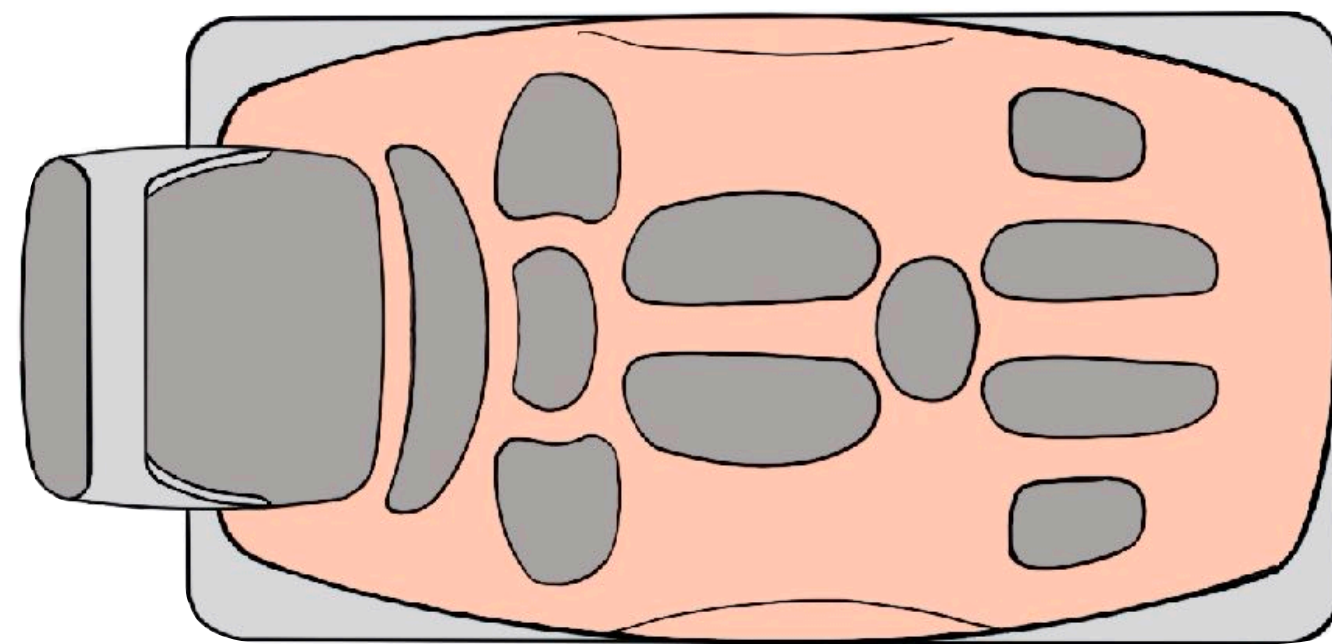
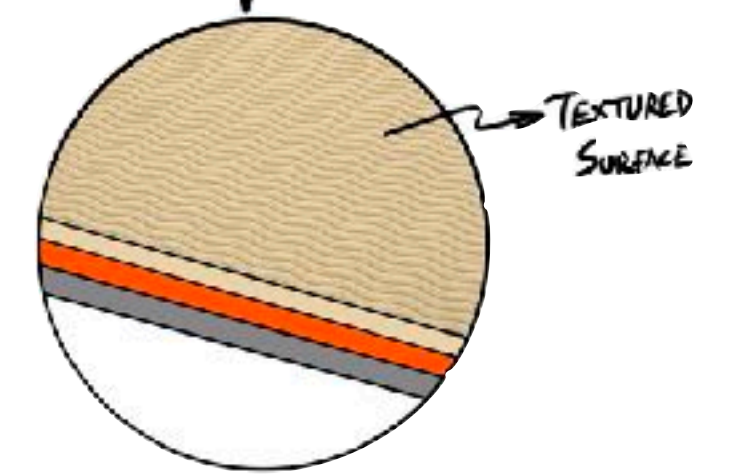
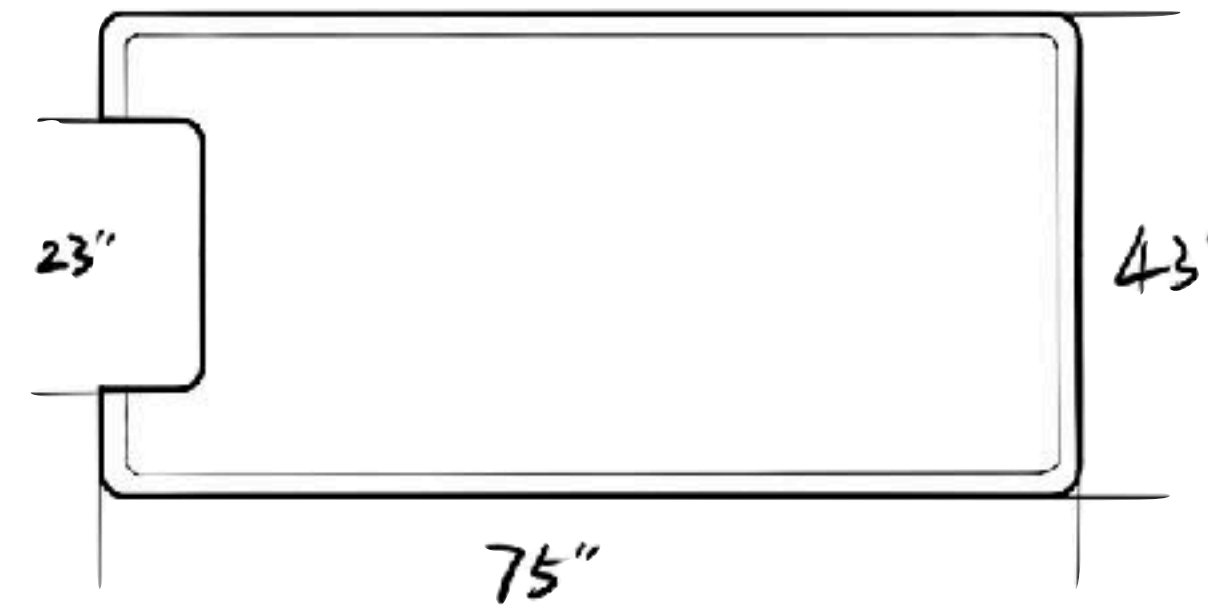
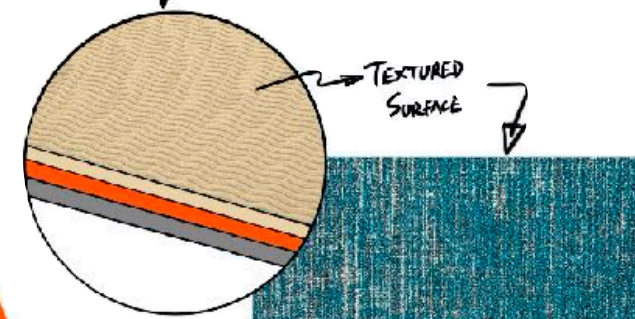
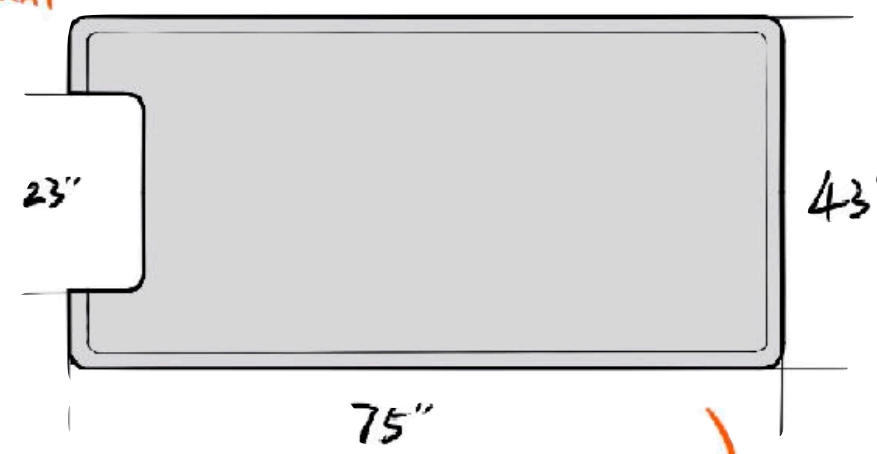

REDUCE THE SIZE & MATCH FOR LANGUAGE

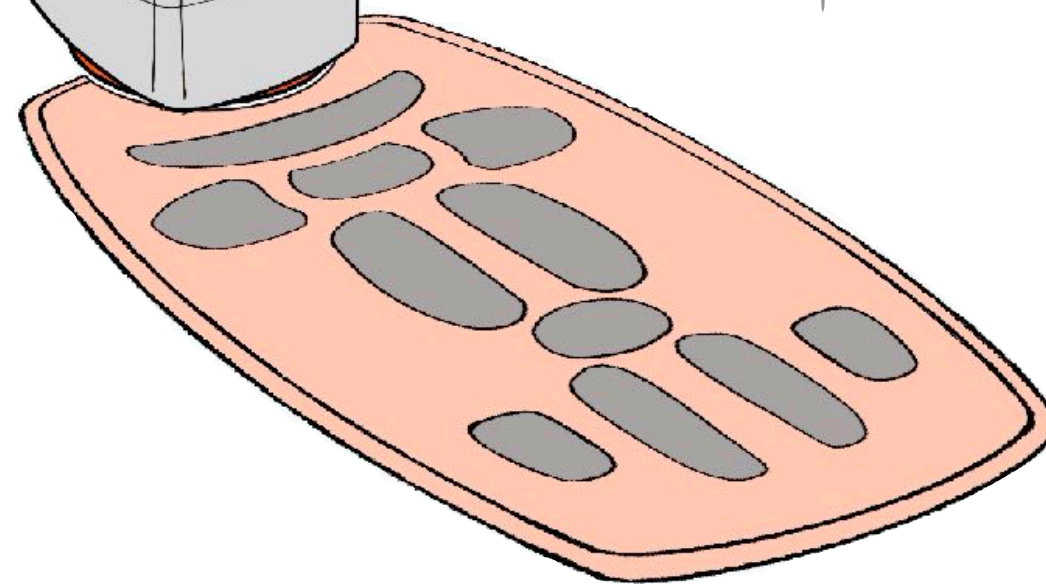

# Ideation development

The training mat



PVC  
Jute layer  
Recycled Rubber

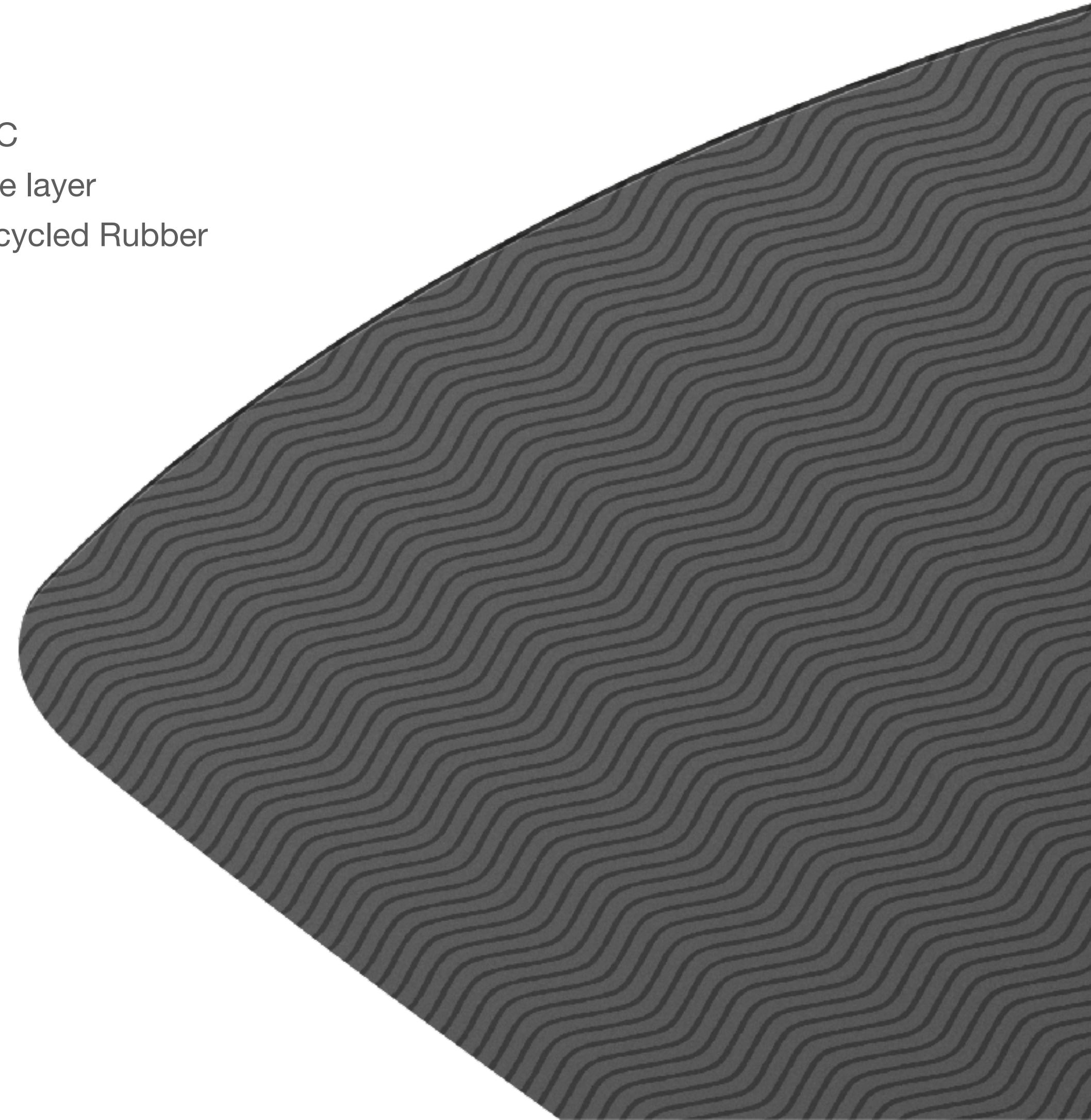

# Ideation development

The training mat

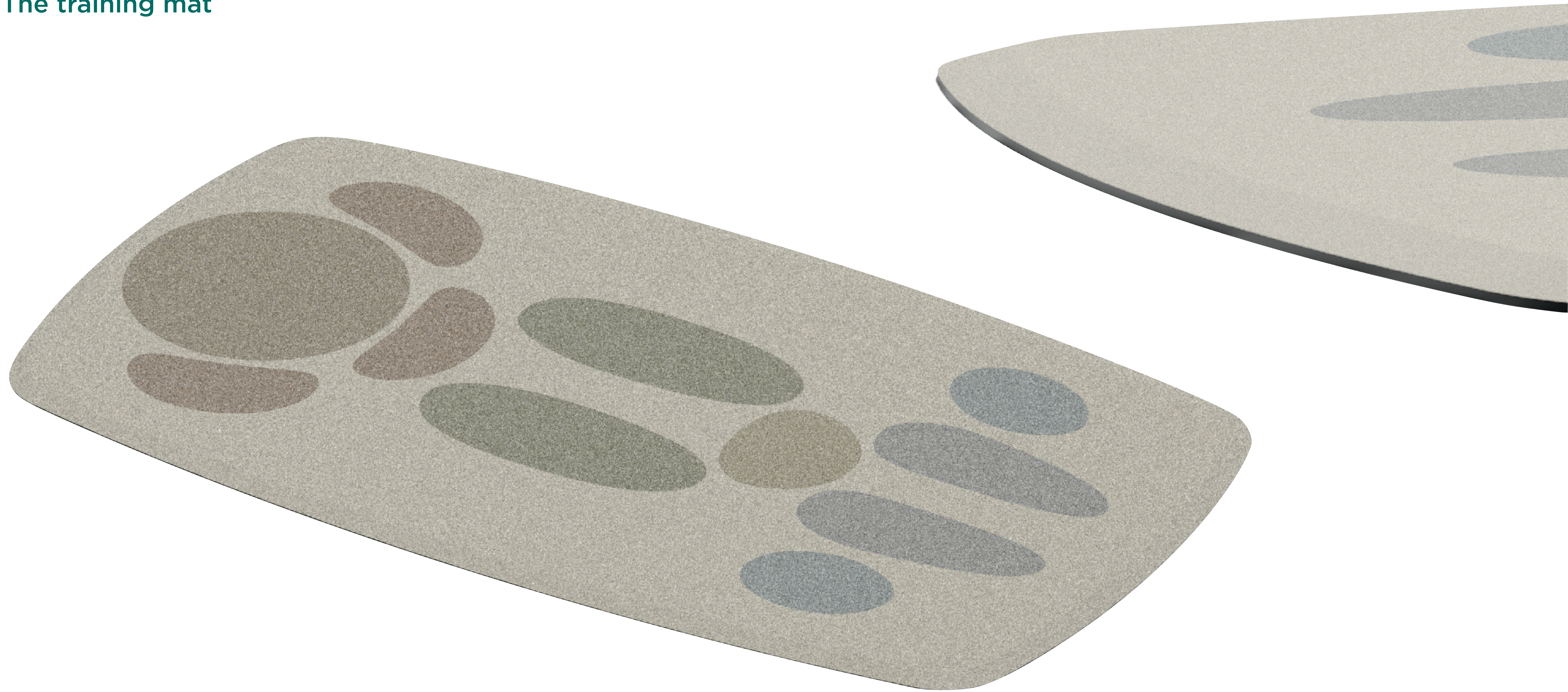

# Ideation development

The training chair



# Ideation development

## Training chair

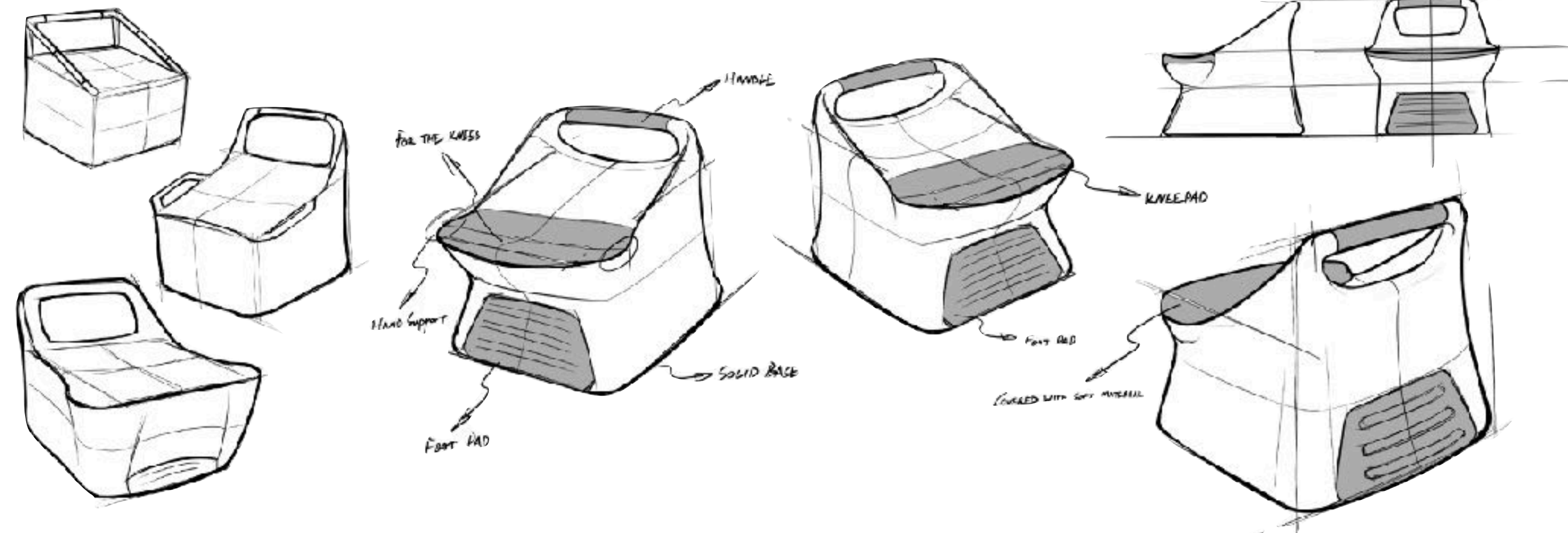
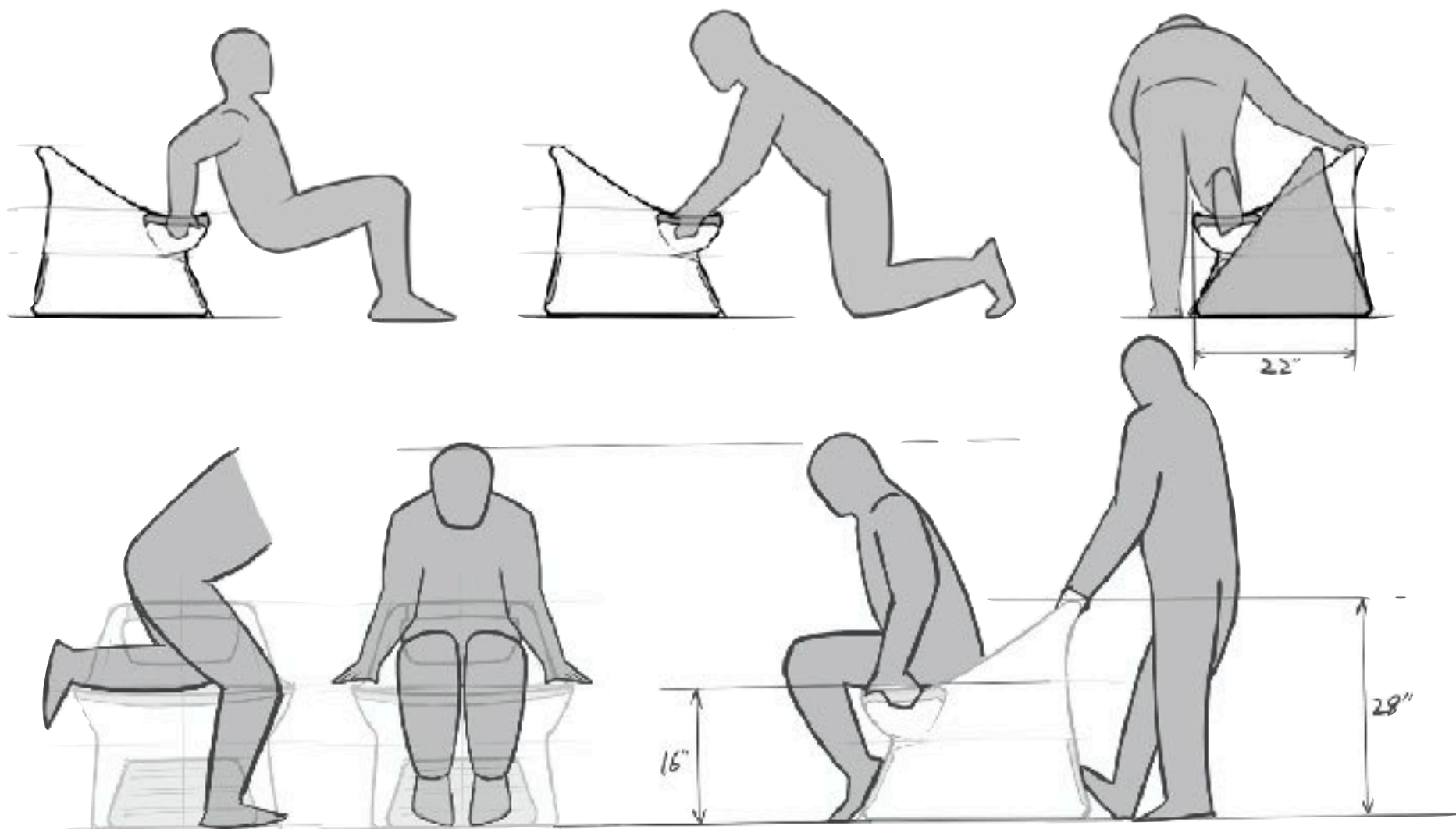
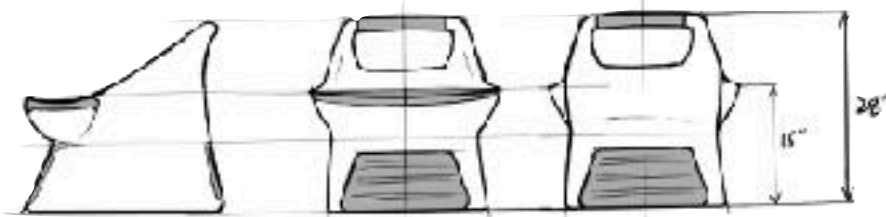
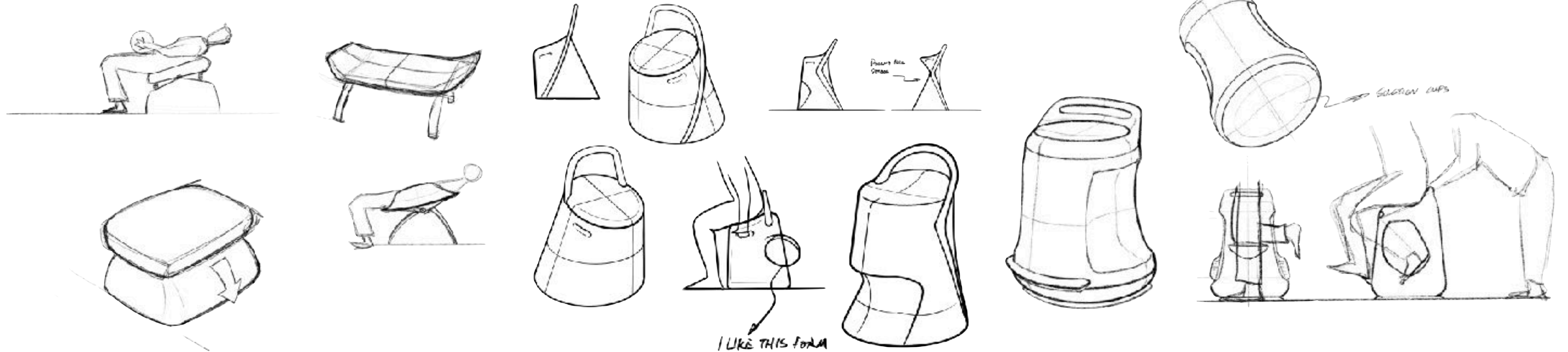

# Ideation development

## Training chair

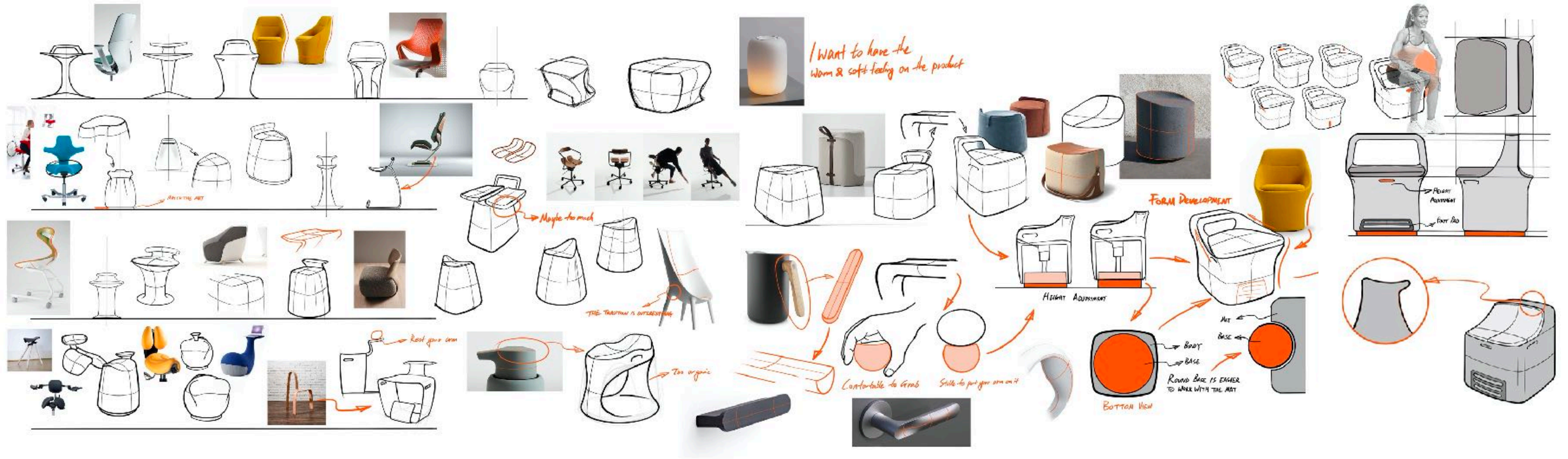

# Ideation development

Training chair



Base weight: 10lb

# Ideation development

Training chair



Height adjustment



# Ideation development

Training chair



Grip

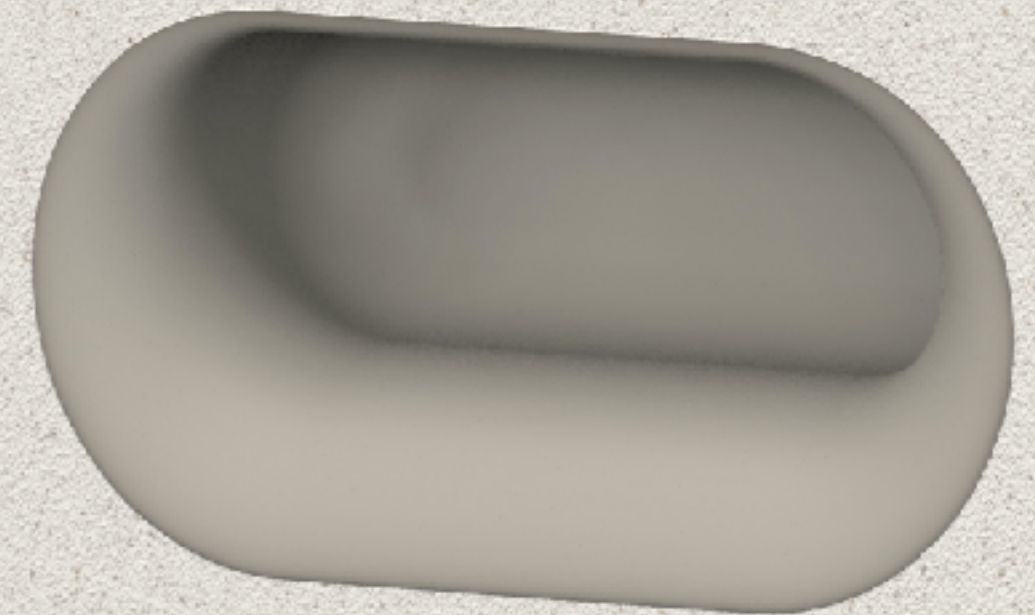

# Ideation development

Training chair



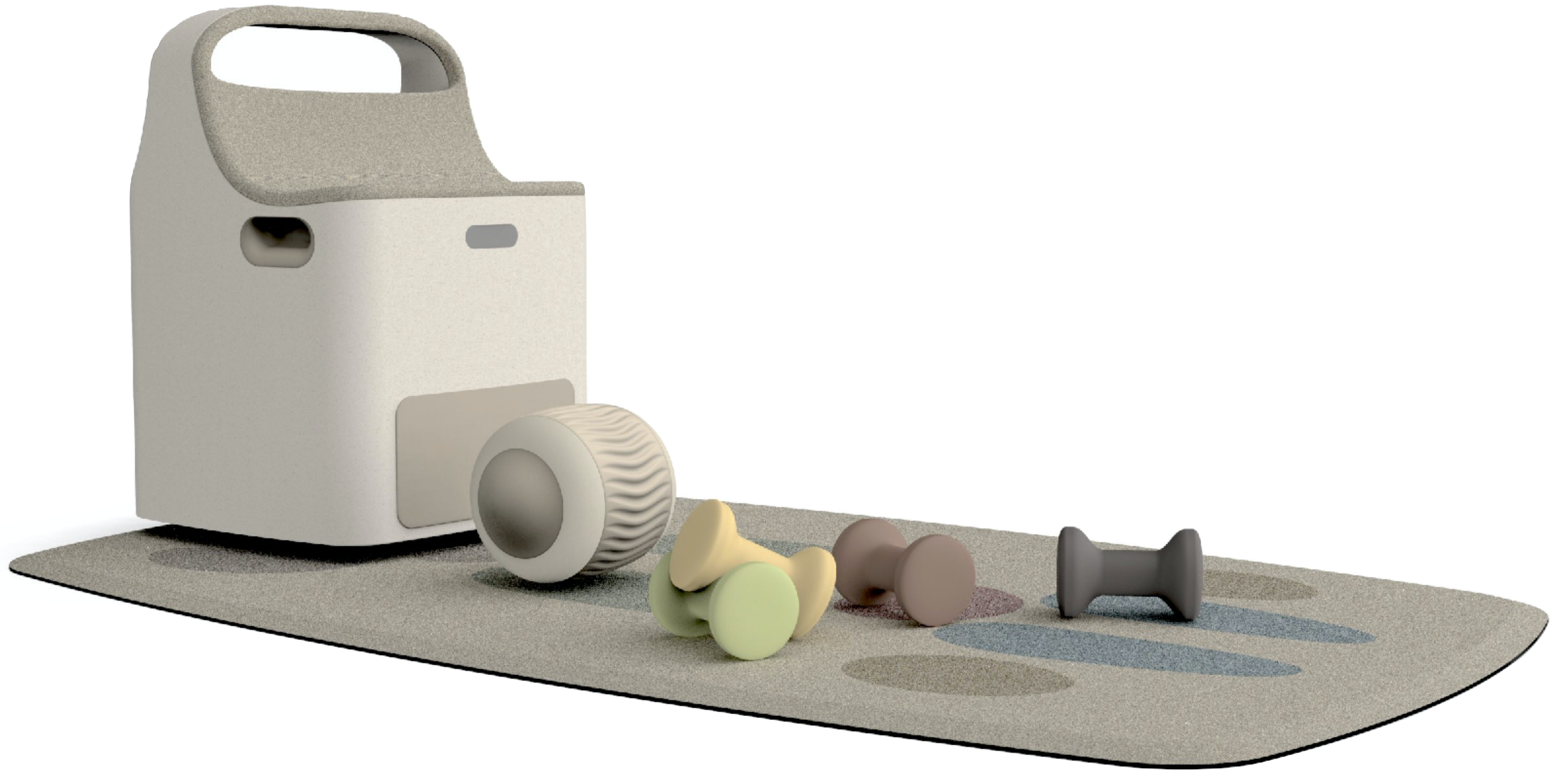

**Thank you!**

